

Mediant 500 E-SBC



Table of Contents

1	Introduction	11
2	Unpacking the Device	13
3	Physical Description	15
3.1	Physical Dimensions	15
3.2	Front Panel Description	15
3.2.1	Ports and Buttons.....	15
3.2.2	LED Descriptions	16
3.2.2.1	Operational Status LED.....	16
3.2.2.2	LAN Interface LED.....	17
3.2.2.3	E1/T1 LEDs	17
3.2.2.4	Power LED.....	17
3.3	Rear Panel Description	18
4	Mounting the Device	19
4.1	Desktop Mounting	19
4.2	Wall Mounting.....	20
4.3	19-Inch Rack Mounting	25
4.3.1	Using a Pre-installed Rack Shelf	25
4.3.2	Using Mounting Brackets	26
5	Cabling the Device	29
5.1	Grounding the Device.....	29
5.2	Connecting to the LAN	30
5.3	Connecting to an ISDN PRI (E1/T1) Trunk	31
5.4	Connecting the Serial Interface to a PC	32
5.5	Connecting a USB Storage Device	33
5.6	Connecting to the Power Supply	34

List of Figures

Figure 3-1: Front Panel	15
Figure 3-2: Rear Panel	18
Figure 4-1: Location for Applying Rubber Feet.....	19
Figure 4-2: Wall-Mounting Bracket Parts.....	20
Figure 4-3: Keyhole Dimensions for Horizontal Wall-Mounting.....	21
Figure 4-4: Keyhole Dimensions for Vertical Wall-Mounting	21
Figure 4-5: Protruded Screw Distance from Wall Surface.....	22
Figure 4-6: Removing Ground Screw	22
Figure 4-7: Removing Side-Panel Screws.....	22
Figure 4-8: Lowering Device into Wall-Mounting Bracket.....	22
Figure 4-9: Device Inserted into Wall-Mounting Bracket	23
Figure 4-10: Attaching Bracket to Device using Grounding Screw	23
Figure 4-11: Attaching Bracket to Device using Ground Screw with Grounding Lug.....	23
Figure 4-12: Attaching Bracket to Device using Side-Panel Screws.....	23
Figure 4-13: Hanging Device on Screw Heads for Horizontal Orientation	24
Figure 4-14: Hanging Device on Screw Heads for Vertical Orientation	24
Figure 4-15: Left Mounting Bracket	26
Figure 4-16: Right Mounting Bracket	26
Figure 4-17: Attaching the Mounting Brackets	27
Figure 5-1: Earthing the Device	29
Figure 5-2: Cabling the LAN Ports.....	30
Figure 5-3: RJ-48c Connector Pinouts for E1/T1	31
Figure 5-4: Cabling E1/T1 Port	31
Figure 5-5: RS-232 Cable Adapter	32
Figure 5-6: Cabling Serial Port	32
Figure 5-7: Connecting a USB Storage Device	33
Figure 5-8: Connecting to the Power Supply	34

List of Tables

Table 3-1: Physical Dimensions	15
Table 3-2: Front Panel Description	16
Table 3-3: STATUS LED Description	16
Table 3-4: LAN LED Description.....	17
Table 3-5: E1/T1 LED Description.....	17
Table 3-6: POWER LED Description	17
Table 3-7: Rear Panel Description.....	18
Table 5-1: RJ-45 Connector Pinouts for GbE	30
Table 5-2: DB-9 to RJ-45 Serial Cable Connector Pinouts	32
Table 5-3: Power Specifications	34

This page is intentionally left blank.

Notice

Information contained in this document is believed to be accurate and reliable at the time of printing. However, due to ongoing product improvements and revisions, AudioCodes cannot guarantee accuracy of printed material after the Date Published nor can it accept responsibility for errors or omissions. Updates to this document can be downloaded from <https://www.audiocodes.com/library/technical-documents>.

This document is subject to change without notice.

Date Published: December-25-2017

WEEE EU Directive

Pursuant to the WEEE EU Directive, electronic and electrical waste must not be disposed of with unsorted waste. Please contact your local recycling authority for disposal of this product.

Customer Support

Customer technical support and services are provided by AudioCodes or by an authorized AudioCodes Service Partner. For more information on how to buy technical support for AudioCodes products and for contact information, please visit our Web site at <https://www.audiocodes.com/services-support/maintenance-and-support>.

Abbreviations and Terminology

Each abbreviation, unless widely used, is spelled out in full when first used.

Throughout this manual, unless otherwise specified, the term *device* refers to Mediant 500 E-SBC.

Related Documentation

Document Name
SIP Release Notes
Mediant 500 E-SBC User's Manual
CLI Reference Guide

General Notes



Note: Open source software may have been added and/or amended for this product. For further information, please visit our website at <http://audiocodes.com/support> or contact your AudioCodes sales representative.

Warnings and Safety Information



Warning: The device is an **INDOOR** unit and thus, must be installed only indoors. In addition, Ethernet port interface cabling must be routed only indoors and must not exit the building.



Caution Electrical Shock

Do not open or disassemble this device. The device carries high voltage and contact with internal components may expose you to electrical shock and bodily harm.



Warning: The device must be installed and serviced only by qualified service personnel.



Warning: For deployment in Finland, Sweden and Norway, the device must be installed **only** in restricted access locations that are compliant with ETS 300253 guidelines where equipotential bonding has been implemented.



Warning: Disconnect the device from the mains and Telephone Network Voltage (TNV) before servicing.

Document Revision Record

LTRT	Description
10388	Max. power consumption updated.
10389	Status LED flashing for upgrade; miscellaneous formatting.
10390	Operating environment specifications updated.
10391	AC power cable warning (Japanese); STATUS LED update.
10392	Wall-mounting added.
10393	Logo updated

Documentation Feedback

AudioCodes continually strives to produce high quality documentation. If you have any comments (suggestions or errors) regarding this document, please fill out the Documentation Feedback form on our Web site at <https://online.audiocodes.com/documentation-feedback>.

This page is intentionally left blank.

1 Introduction

This document provides a hardware description of the Mediant 500 E-SBC (hereafter referred to as *device*) and step-by-step procedures for mounting and cabling the device.

The device supports the following interfaces:

- Four Gigabit Ethernet (10/100/1000Base-T) LAN ports
- Single E1/T1 port interface over a single copper wire pair (PRI interface is a customer-ordered item)
- Two USB ports for optional, USB storage services
- Serial console port (RJ-45) for device management

**Notes:**

- Hardware configurations may change without notice. Currently available hardware configurations are listed in AudioCodes Price Book. For further enquiries, please contact your AudioCodes sales representative.
- For information on configuring the device, refer to the device's *User's Manual*.

This page is intentionally left blank.

2 Unpacking the Device

Follow the procedure below for unpacking the carton in which the device was shipped.

➤ **To unpack the device:**

1. Open the carton and carefully remove packing materials.
2. Remove the chassis from the carton.
3. Check that there is no equipment damage.
4. Ensure that in addition to the chassis, the package contains the following items:
 - Four anti-slide bumpers for desktop installation
 - Two mounting brackets for 19-inch rack mounting
 - Serial cable adapter
 - One AC power cable
 - (Optional) Wall-mounting kit (customer-ordered item)
5. Check, retain and process any documents.

If there are any damaged or missing items, notify your AudioCodes sales representative.

This page is intentionally left blank.

3 Physical Description

This section provides a physical description of the device.

3.1 Physical Dimensions

The device's physical dimensions and weight are listed in the table below:

Table 3-1: Physical Dimensions

Physical Specification	Value
Dimensions (H x W x D)	4.37 (1U) x 31.0 cm x 21.0 cm (1.72 x 12.2 x 8.3 in.)
Weight	2.0 kg (4.4 lbs.)
Environmental	<ul style="list-style-type: none"> ▪ Operational: 0 to 40°C (32 to 104°F) ▪ Storage: -25 to 70°C (-13 to 158°F) ▪ Humidity: 10 to 90% non-condensing

3.2 Front Panel Description

This section describes the device's front panel.

3.2.1 Ports and Buttons

The device's front panel is shown in the figure below and described in the subsequent table.

Figure 3-1: Front Panel



Table 3-2: Front Panel Description

Item #	Label	Description
1	POWER / STATUS	LEDs indicating the status of the power and reboot/initialization. For more information, see Section 3.2.2 on page 16.
2	//	Reset pinhole button for resetting the device and optionally, for restoring the device to factory defaults. To restore the device to factory defaults, do the following: With a paper clip or any other similar pointed object, press and hold down the pinhole button for at least 12 seconds, but no longer than 25 seconds
3	CONSOLE	RJ-45 port for RS-232 serial communication
4	LAN	Up to four Gigabit Ethernet (10/100/1000Base-T) ports for connecting to LAN network (IP phones, computers, or switches). These ports support half- and full-duplex modes, auto-negotiation, and straight or crossover cable detection.
5	PRI	Single E1/T1 port interface (RJ-48). Note: PRI interface is a customer-ordered item.
6	USB	Two USB 2.0 ports, which can be used, for example, for various storage capabilities using an external USB hard drive or flash disk (disk on key).

3.2.2 LED Descriptions

This section describes the LEDs provided on the front panel.

3.2.2.1 Operational Status LED

The **STATUS** LED indicates the operating status, as described in the table below.

Table 3-3: STATUS LED Description

LED Color	LED State	Description
Green	On	Device is operational.
	Fast Flashing	<ul style="list-style-type: none"> ▪ Initial rebooting stage. ▪ Software upgrade (.cmp file) in process (currently supported only by Software Version 6.8).
Red	On	Boot failure.
-	Off	Advanced rebooting stage.

3.2.2.2 LAN Interface LED

Each Ethernet port provides a LED for indicating LAN operating status, as described in the table below.

Table 3-4: LAN LED Description

LED Color	LED State	Description
Green	On	Ethernet link established.
	Flashing	Data is being received or transmitted.
-	Off	No Ethernet link.

3.2.2.3 E1/T1 LEDs

The E1/T1 trunk port provides a LED for indicating operating status, as described in the table below:

Table 3-5: E1/T1 LED Description

Color	State	Description
Green	On	Trunk is synchronized (normal operation).
Red	On	Loss due to any of the following signals: <ul style="list-style-type: none"> ▪ LOS - Loss of Signal ▪ LOF - Loss of Frame ▪ AIS - Alarm Indication Signal (the Blue Alarm) ▪ RAI - Remote Alarm Indication (the Yellow Alarm)
-	Off	Failure / disruption in the AC power supply or the power is currently not being supplied to the device through the AC power supply entry.

3.2.2.4 Power LED

The **POWER** LED indicates the power supply status, as described in the table below.

Table 3-6: POWER LED Description

LED Color	LED State	Description
Green	On	Power is received by the device.
-	Off	No power received by the device.

3.3 Rear Panel Description

The device's rear panel is shown in the figure below and described in the subsequent table.

Figure 3-2: Rear Panel

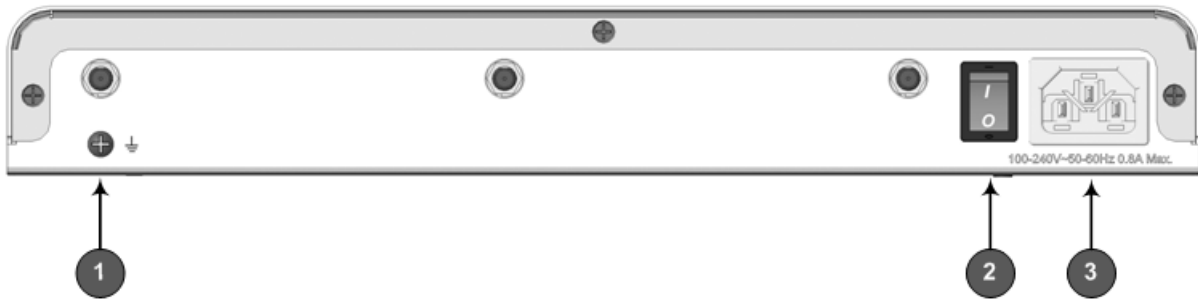



Table 3-7: Rear Panel Description

Item #	Label	Description
1		Protective earthing screw.
2	I / O	Power switch (O is off; I is on).
3	100-240V~50-60Hz 0.8A Max.	Three-prong AC power supply entry.

4 Mounting the Device

The device can be mounted in one of the following ways:

- Placed on a desktop – see Section 4.1 on page 19
- Installed in a standard 19-inch rack – see Section 4.2 on page 20



Warning: Do not place any equipment directly on top of the device or adjacent to its sides (at least 13-cm separation). In addition, if you are mounting the device in a 19-inch rack, ensure that at least a 3U separation is maintained between the device and other mounted devices or equipment.

4.1 Desktop Mounting

The device can be placed on a desktop when its four anti-slide bumpers (supplied) are attached to the underside of the device.

➤ **To attach the anti-slide rubber bumpers to the device:**

1. Flip the device over so that its underside faces up.
2. Locate the four anti-slide grooves on the underside - one in each corner.
3. Peel off the adhesive, anti-slide rubber feet and stick one in each anti-slide groove.

Figure 4-1: Location for Applying Rubber Feet

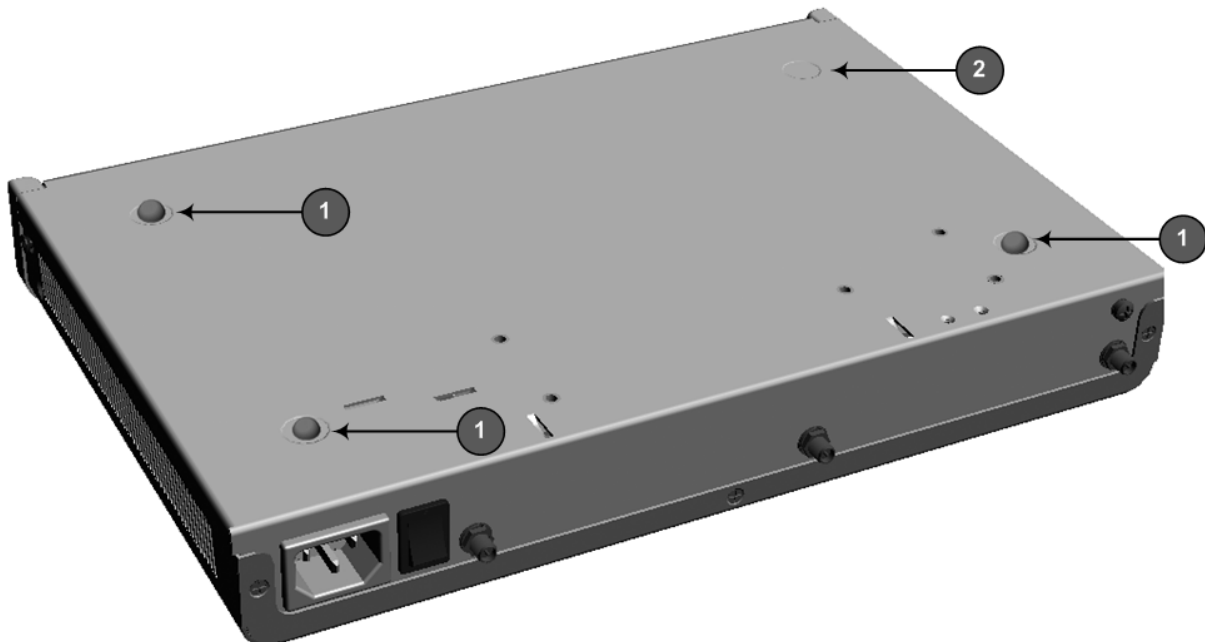

- 1 = Mounted anti-slide rubber feet
 - 2 = Anti-slide groove
4. Flip the device over again so that it rests on the rubber feet and place it in the required position on a desktop.

4.2 Wall Mounting

You can mount the device on a wall, using a special wall-mounting bracket. The bracket enables you to hang the device in a horizontal (rear panel facing up) or vertical (rear panel facing right) position. The bracket is a customer-ordered item and is shipped in a kit of five wall-mounting brackets. The areas of the wall-mounting bracket are shown below:

Figure 4-2: Wall-Mounting Bracket Parts

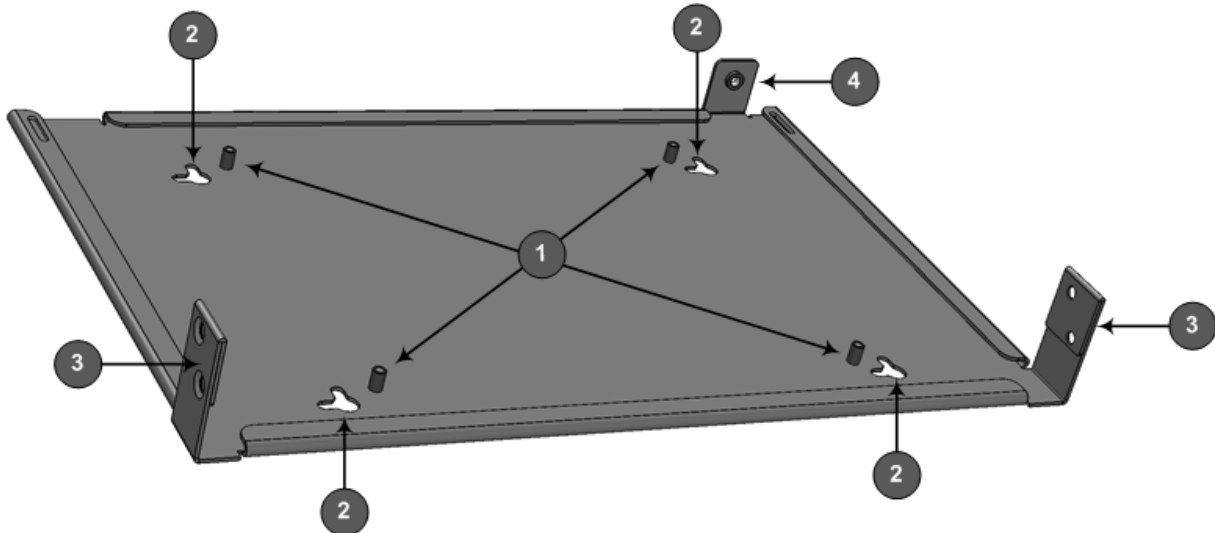

- 1 - Spacers to separate the device from the bracket.
- 2 - Keyholes for hanging the bracket on the wall.
- 3 - Screw-holes for attaching the bracket to the device's side panels
- 4 - Ground-screw hole for attaching the bracket to the device's grounding hole.



Note: When choosing the area on the wall to mount the device, make sure that sufficient space is available for attaching the cables on the front and rear panels.

➤ **To mount the device on a wall:**

1. Mark the drilling locations of the four mounting holes on the wall. You can use the wall-mounting bracket as a template. Place the bracket flat against the wall in the desired hanging orientation - horizontal or vertical (see figures below). Make sure that the bracket is horizontal with the floor (you can use a level). With a pencil, stencil the keyholes on the wall.

The distances between the keyholes depend on the orientation in which you want to hang the device:

- **Horizontal position:** The horizontal distance between the keyholes is 200 mm (7.87 in.) and the vertical distance is 135 mm (5.31 in.):

Figure 4-3: Keyhole Dimensions for Horizontal Wall-Mounting

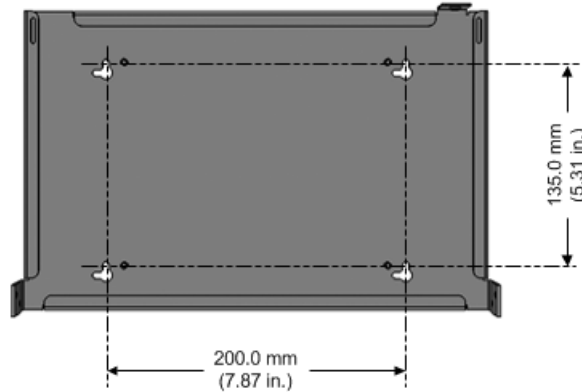

- **Vertical position:** The horizontal distance between the keyholes is 135 mm (5.31 in.) and the vertical distance is 200 mm (7.87 in.):

Figure 4-4: Keyhole Dimensions for Vertical Wall-Mounting

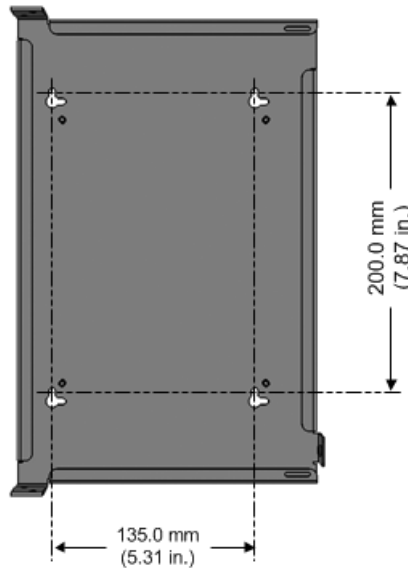

2. Drill holes in the wall where you marked the keyholes.
3. Insert wall anchors of appropriate size into each drilled hole.
4. Thread screws (not supplied) into each of the wall anchors. The recommended screw type is DIN 7982 3.5x25 Phillips flat head. Make sure that the heads of the screws extend sufficiently (about 4 mm or 0.157 in.) from the wall to allow you to hang the bracket's keyholes:

Figure 4-5: Protruded Screw Distance from Wall Surface

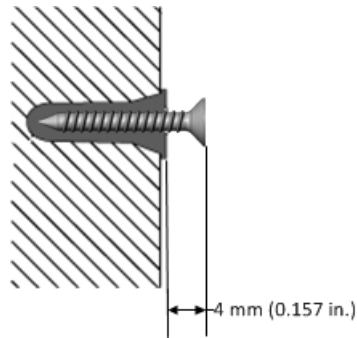

5. Using a Phillips-head screwdriver, remove the grounding-lug screw located on the rear panel (keep the screw in a safe place for later use):

Figure 4-6: Removing Ground Screw



6. Using a Phillips-head screwdriver, remove the two screws located on the left- and right-side panels (keep the screws in a safe place for later use):

Figure 4-7: Removing Side-Panel Screws



7. Place the bracket on a flat surface, and then with two hands, hold the device above the bracket so that its bottom panel faces the bracket and its rear panel is on the same side as the bracket's grounding-screw hole. Gently lower the device into the bracket until it snaps into place:

Figure 4-8: Lowering Device into Wall-Mounting Bracket

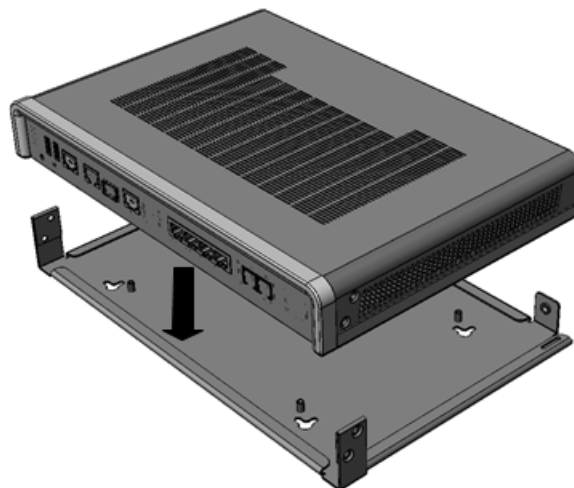
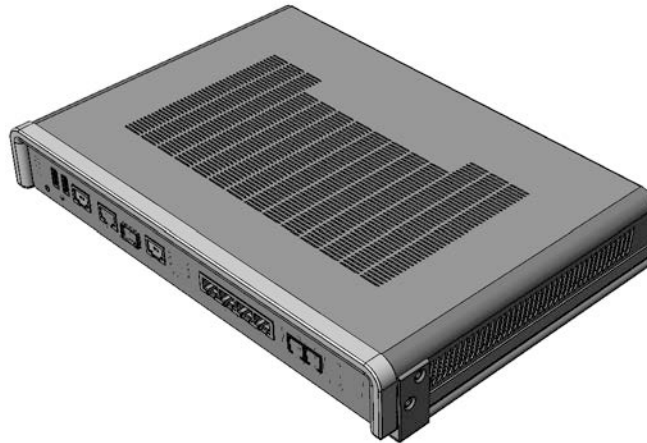
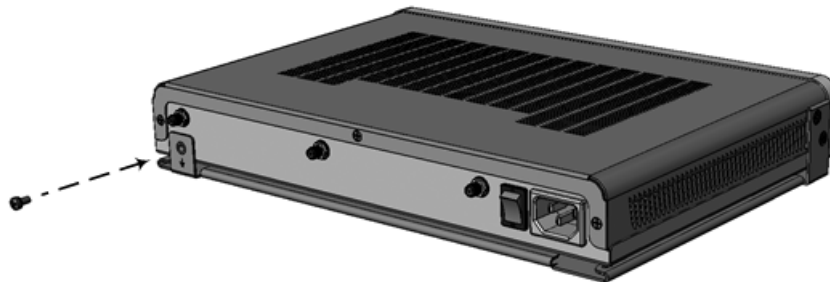
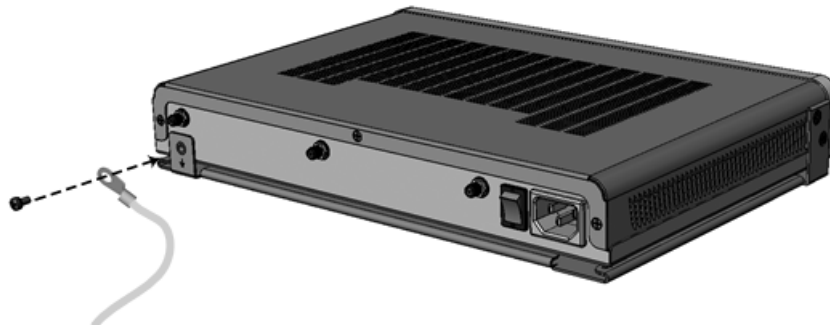

Figure 4-9: Device Inserted into Wall-Mounting Bracket

8. Using a Phillips-head screwdriver, attach the bracket to the rear panel, using the grounding-lug screw (which you removed in Step 65):

Figure 4-10: Attaching Bracket to Device using Grounding Screw

If you are grounding the device, attach the grounding lug at the same time:

Figure 4-11: Attaching Bracket to Device using Ground Screw with Grounding Lug

9. Using a Phillips-head screwdriver, attach the bracket to the left- and right-side panels, using two screws for each side (which you removed in Step 6):

Figure 4-12: Attaching Bracket to Device using Side-Panel Screws

10. With two hands, hold the device (attached to the bracket) so that the bracket's keyholes are facing the screw heads in the wall and that the device is orientated according to the desired hanging position (horizontal or vertical). Gently hang the device onto the screw heads, using the bracket's keyholes:

Figure 4-13: Hanging Device on Screw Heads for Horizontal Orientation

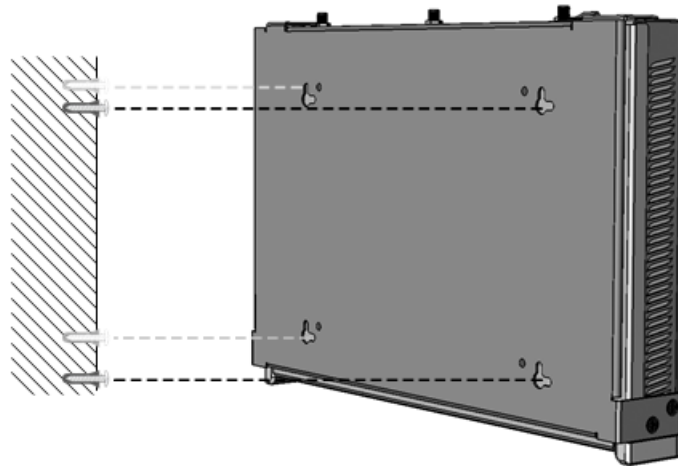
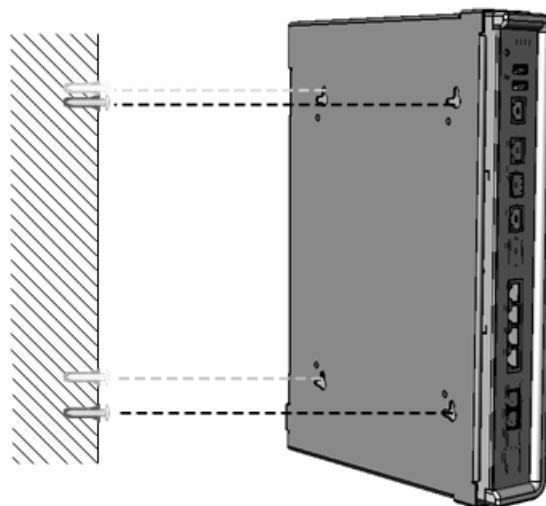

Figure 4-14: Hanging Device on Screw Heads for Vertical Orientation



4.3 19-Inch Rack Mounting

The device can be installed in a standard 19-inch rack by implementing one of the following mounting methods:

- Placing it on a pre-installed shelf in a 19-inch rack – see Section 4.3.1 on page 25
- Attaching it directly to the rack's frame using the device's mounting brackets (supplied) that need to be attached to the chassis – see Section 4.3.2 on page 26



Rack Mount Safety Instructions

When installing the chassis in a rack, implement the following safety instructions:

- **Elevated Operating Ambient Temperature:** If installed in a closed or multi-unit rack assembly, the operating ambient temperature of the rack environment may be greater than room ambient temperature. Therefore, consideration should be given to installing the equipment in an environment with maximum ambient temperature (T_{ma}) of 40°C (104°F).
- **Reduced Air Flow:** Installation of the equipment in a rack should be such that the amount of air flow required for safe operation on the equipment is not compromised.
- **Mechanical Loading:** Mounting of the equipment in the rack should be such that a hazardous condition is not achieved due to uneven mechanical loading.
- **Circuit Overloading:** Consideration should be given to the connection of the equipment to the supply circuit and the effect that overloading of the circuits might have on over-current protection and supply wiring. Appropriate consideration of equipment nameplate ratings should be used when addressing this concern.
- **Reliable Earthing:** Reliable earthing of rack-mounted equipment should be maintained. Particular attention should be given to supply connections other than direct connections to the branch circuit (e.g., use of power strips). For earthing the device, see Section 5.1 on page 29.

4.3.1 Using a Pre-installed Rack Shelf

The procedure below describes how to place the device on a pre-installed shelf in a 19-inch rack.

- **To mount the device on a pre-installed shelf in the rack:**
 1. Before installing it in the rack, ensure that you have a pre-installed rack shelf on which the device can be placed.
 2. Place the device on the pre-installed shelf in the rack.

4.3.2 Using Mounting Brackets

The procedure below describes how to mount the device in a 19-inch rack. Rack mounting involves placing the device on a pre-installed rack shelf and then attaching the device's mounting brackets to the device and rack frame. The purpose of the mounting brackets is to secure the device to the rack.

Two mounting brackets are provided:

- Left mounting bracket:

Figure 4-15: Left Mounting Bracket



- Right mounting bracket with hole for looping through an optional cable tie (not supplied) for securing cables:

Figure 4-16: Right Mounting Bracket

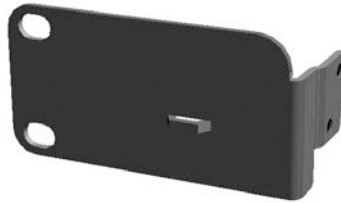

➤ **To mount the device in a 19-inch rack using mounting brackets:**

1. Attach the two mounting brackets (supplied) to each side of the device's chassis, using the supplied screws, as shown in the figure below:

Figure 4-17: Attaching the Mounting Brackets

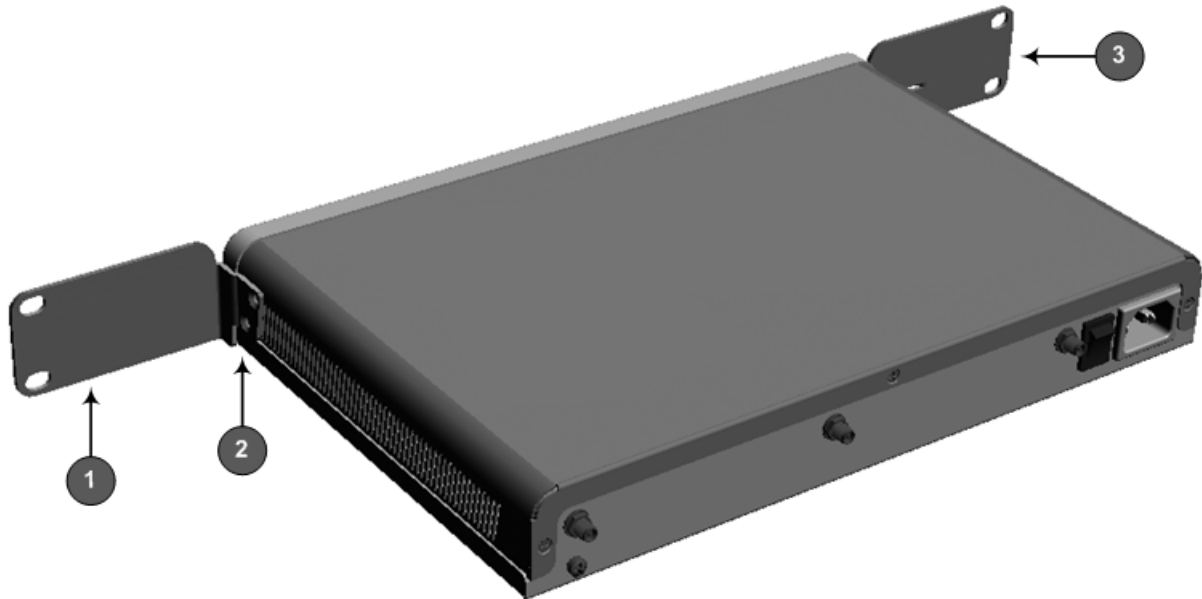

- 1 = Left mounting bracket
 - 2 = Attached screws
 - 3 = Right mounting bracket
2. Place the device on a pre-installed shelf in the rack.
 3. Attach the ends of the mounting brackets (that you installed in Step 1) to the vertical track of the rack's frame, using standard 19-inch rack bolts (not supplied).

This page is intentionally left blank.

5 Cabling the Device

This section describes the cabling of the device, which includes the following:

- Grounding (earthing) the device – see Section 5.1 on page 29
- Connecting to the LAN – see Section 5.2 on page 30
- Connecting to an E1/T1 trunk – see Section 5.3 on page 31
- Connecting to a computer for serial communication – see Section 5.4 on page 32
- Connecting a USB storage device – see Section 5.5 on page 31
- Connecting to the power supply – see Section 5.6 on page 34

5.1 Grounding the Device

The device must be connected to earth (grounded) using an equipment-earthing conductor.



Protective Earthing

The equipment is classified as Class I EN60950 and UL60950 and must be earthed at all times.

For Finland: "Laite on liltettava suojavaadoituskoskettimilla varustettuun pistorasiaan."

For Norway: "Apparatet rna tilkoples jordet stikkontakt."

For Sweden: "Apparaten skall anslutas till jordat uttag."

➤ To earth the device:

1. Connect an electrically earthed strap of 16 AWG wire (minimum) to the chassis' earthing screw (located on the rear panel), using the supplied washer.
2. Connect the other end of the strap to a protective earthing. This should be in accordance with the regulations enforced in the country of installation.

Figure 5-1: Earthing the Device

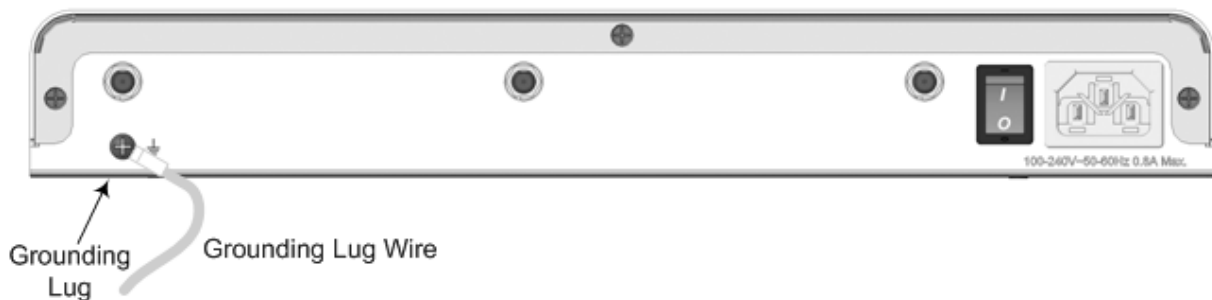

5.2 Connecting to the LAN

The device provides up to four Gigabit Ethernet (10/100/1000Base-T) ports for connection to the LAN (e.g., computers, switches, and IP phones). These ports support half- and full-duplex modes, auto-negotiation, and straight or crossover cable detection.

The RJ-45 connector pinouts are described in the table below:

Table 5-1: RJ-45 Connector Pinouts for GbE

Pin	Signal Name
1	Ethernet signal pair (10/100/1000Base-T)
2	
3	Ethernet signal pair (10/100/1000Base-T)
6	
4	Ethernet signal pair (1000Base-T)
5	
7	Ethernet signal pair (1000Base-T)
8	
Shield	Chassis ground

➤ **To connect the device to the LAN:**

1. Connect one end of a straight-through RJ-45 Cat 5e or Cat 6 cable to the RJ-45 port labeled **S1 / LAN GE**.

Figure 5-2: Cabling the LAN Ports

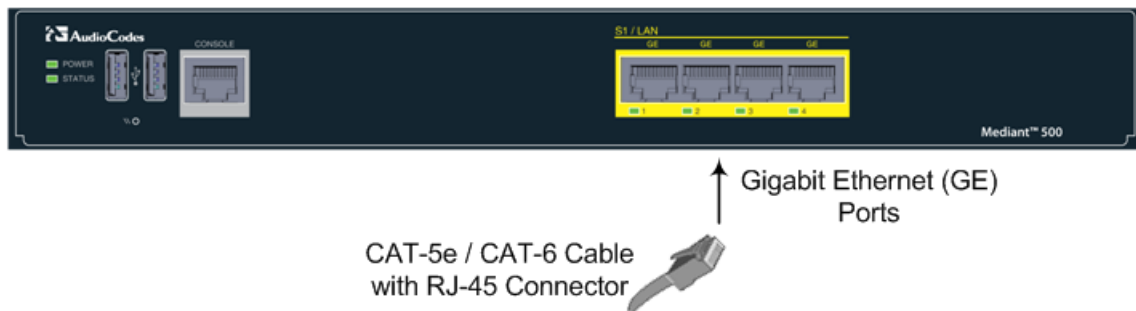

2. Connect the other end of the cable to the Gigabit Ethernet network.

5.3 Connecting to an ISDN PRI (E1/T1) Trunk

The procedure below describes the cabling of the device's E1/T1 (PRI) trunk interface.



Warning: To protect against electrical shock and fire, use a 26 AWG min wire to connect the E1 / T1 port to the PSTN.



Note: PRI interface is a customer-ordered item.

The RJ-48c trunk connector used in the cabling is wired according to the figure below:

Figure 5-3: RJ-48c Connector Pinouts for E1/T1

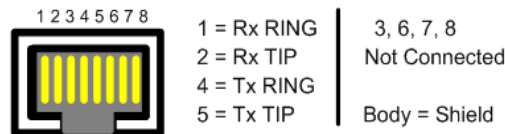

➤ **To connect the E1/T1 trunk interface:**

1. Connect the E1/T1 trunk cable to the device's E1/T1 port.
2. Connect the other end of the trunk cable to your PBX/PSTN switch.

Figure 5-4: Cabling E1/T1 Port

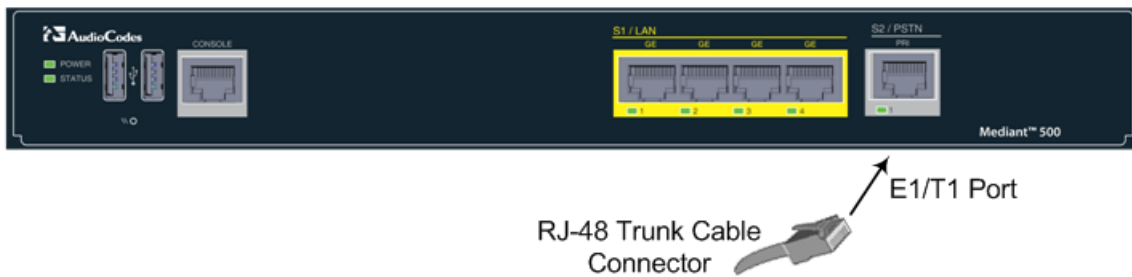

5.4 Connecting the Serial Interface to a PC

The device provides an RS-232 serial interface port on its front panel. The serial cable adapter used for connecting the RS-232 interface is shown below:

Figure 5-5: RS-232 Cable Adapter

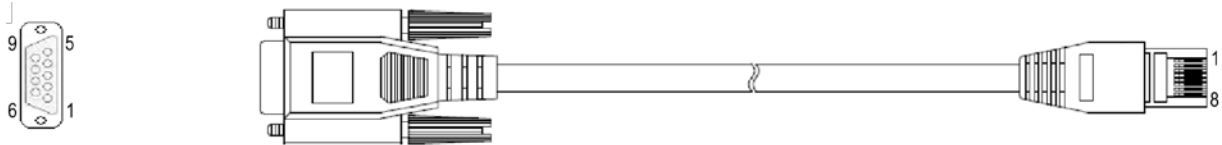

Table 5-2: DB-9 to RJ-45 Serial Cable Connector Pinouts

DB-9 Female	RJ-45
8	1
6	2
2	3
5	4
5	5
3	6
4	7
7	8

➤ **To connect the device's serial interface port to a PC:**

1. Connect the end of the cable providing the RJ-45 connector to the device's serial port located on the front panel, labeled **CONSOLE**.

Figure 5-6: Cabling Serial Port

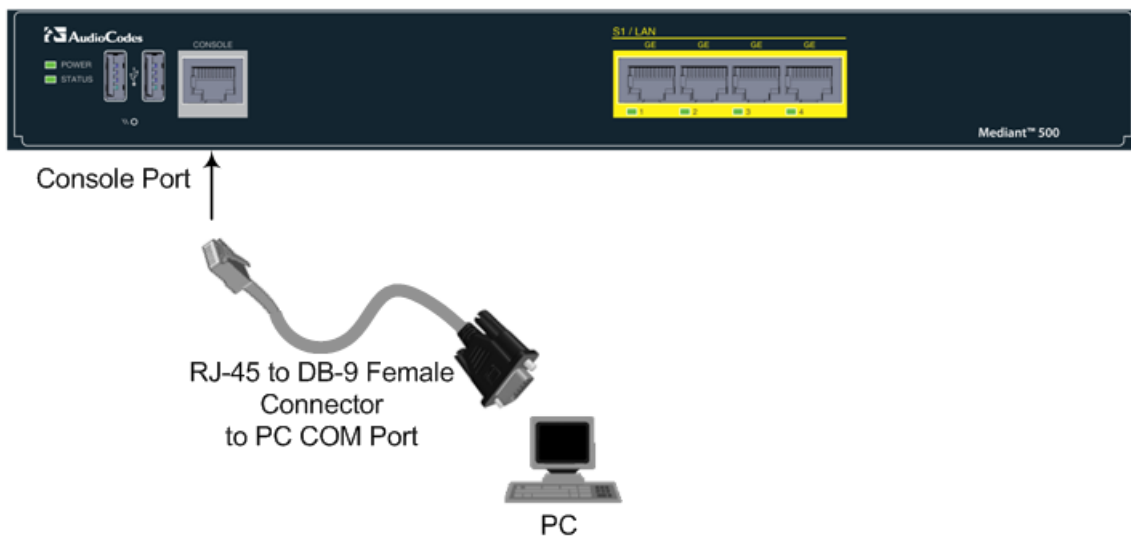

2. Connect the other end of the cable providing the 9-pin DB connector to the COM RS-232 communication port on your computer.

5.5 Connecting a USB Storage Device

The device supports USB storage capabilities, using an external USB hard drive or flash disk (disk on key) connected to the device's USB port. The storage capabilities are configured through CLI and include the following:

- Saving network captures to the USB
 - Updating the device's firmware from the USB
 - Updating the device's configuration from the USB
 - Saving the current configuration to the USB
- **To connect the USB storage device:**
- Connect the USB storage device to one of the USB ports located on the front panel.

Figure 5-7: Connecting a USB Storage Device

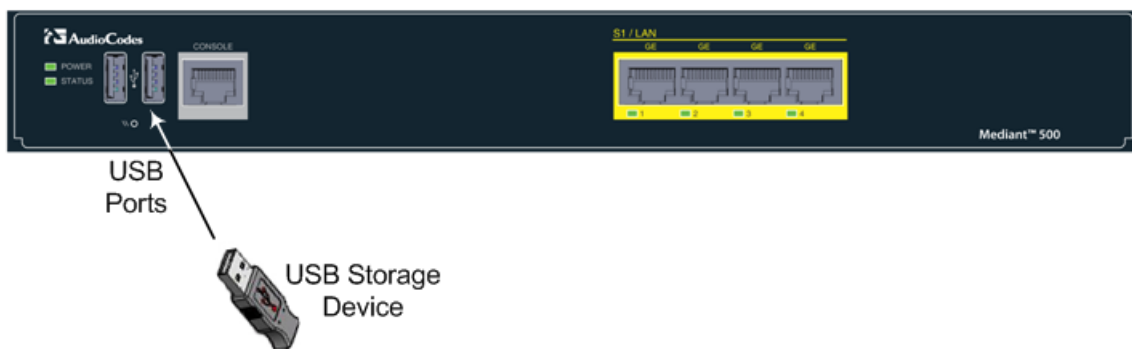

Note: Only a single USB storage (formatted to FAT/FAT32) operation is supported at any given time.

5.6 Connecting to the Power Supply

The device receives power from a standard alternating current (AC) electrical outlet. The connection is made using the supplied AC power cord.

Table 5-3: Power Specifications

Physical Specification	Value
Input Voltage	Single universal AC power supply 100 to 240V
AC Input Frequency	50 to 60 Hz
AC Input Current	0.8A
Max. Power Consumption	20W



Warnings:

- The device must be connected to a socket-outlet providing a protective earthing connection.
- Use only the AC power cord that is supplied with the device.



ご注意

本製品に添付の電源ケーブルは、Mediant 500 E-SBC に専用設計されているため、汎用性はありません。本電源ケーブルを他の機器に使用されないよう、ご注意ください。

➤ **To connect the device to the power supply:**

1. Connect the line socket of the AC power cord (supplied) to the device's AC power socket (labeled **100-240V~50-60 Hz 0.8A**), located on the rear panel.

Figure 5-8: Connecting to the Power Supply



2. Connect the plug at the other end of the AC power cord to a standard electrical outlet.
3. Press the power switch to on (I) position so that the device receives power; the **POWER** LED on the front panel is lit green (for more information, see Section 3.2.2.4 on page 17).

This page is intentionally left blank.

International Headquarters

1 Hayarden Street,
Airport City
Lod 7019900, Israel
Tel: +972-3-976-4000
Fax: +972-3-976-4040

AudioCodes Inc.

27 World's Fair Drive,
Somerset, NJ 08873
Tel: +1-732-469-0880
Fax: +1-732-469-2298

Contact us: <https://www.audiocodes.com/corporate/offices-worldwide>

Website: <https://www.audiocodes.com/>

©2017 AudioCodes Ltd. All rights reserved. AudioCodes, AC, HD VoIP, HD VoIP Sounds Better, IPmedia, Mediant, MediaPack, What's Inside Matters, OSN, SmartTAP, User Management Pack, VMAS, VoIPerfect, VoIPerfectHD, Your Gateway To VoIP, 3GX, VocaNom, AudioCodes One Voice and CloudBond are trademarks or registered trademarks of AudioCodes Limited. All other products or trademarks are property of their respective owners. Product specifications are subject to change without notice.

Document #: LTRT-10393

