

# Mediant 500L

## Enterprise Session Border Controller (E-SBC) and Media Gateway





---

## Table of Contents

---

<b>1</b>	<b>Introduction.....</b>	<b>9</b>
<b>2</b>	<b>Unpacking the Device .....</b>	<b>11</b>
<b>3</b>	<b>Physical Description .....</b>	<b>13</b>
3.1	Physical Dimensions and Operating Environment .....	13
3.2	Front Panel Description .....	13
3.2.1	LED Descriptions .....	14
3.2.1.1	Power LED.....	14
3.2.1.2	Status LED.....	14
3.3	Rear Panel Description .....	15
3.3.1	LAN Interface LEDs .....	16
<b>4</b>	<b>Mounting the Device .....</b>	<b>17</b>
4.1	19-Inch Rack Mounting .....	17
4.2	Wall Mounting.....	20
<b>5</b>	<b>Cabling the Device .....</b>	<b>23</b>
5.1	Connecting LAN Interfaces .....	23
5.2	ISDN BRI Interfaces .....	25
5.2.1	Connecting BRI Lines .....	25
5.2.2	Connecting PSTN Fallback for BRI Lines .....	27
5.3	Analog Interfaces .....	28
5.3.1	Connecting FXS Interfaces .....	28
5.3.2	Connecting FXO Interfaces.....	29
5.3.3	Connecting the FXS Analog Lifeline .....	31
5.4	Cabling the Serial Interface to a PC .....	32
5.5	Connecting a USB Storage Device .....	33
5.6	Connecting to the Power Supply .....	34
5.6.1	Powering On or Off the Device .....	37

## List of Figures

Figure 3-1: Front Panel .....	13
Figure 3-2: Rear Panel .....	15
Figure 4-1: Minimum Vertical Space for 19-inch Rack Mounting .....	17
Figure 4-2: Positioning Shelf in Rack.....	18
Figure 4-3: Positioning the Device's Anti-Slide Rubber Legs into Shelf's Openings.....	19
Figure 4-4: Device Mounted on Shelf in 19-inch Rack .....	19
Figure 4-5: Dimensions for Drilled Holes.....	20
Figure 4-6: Protruded Screw Distance from Wall Surface.....	22
Figure 4-7: Hanging Device on Screw Heads .....	22
Figure 5-1: Default Ethernet Port Groups and Port String Names for Software Configuration .....	23
Figure 5-2: Cabling LAN Ports.....	24
Figure 5-3: RJ-45 Connector Pinouts for TE or NT BRI Ports.....	25
Figure 5-4: Cabling BRI Ports.....	26
Figure 5-5: Cabling BRI PSTN Fallback .....	27
Figure 5-6: RJ-11 Connector Pinouts for FXS Interface.....	28
Figure 5-7: Connecting FXS Interfaces .....	29
Figure 5-8: RJ-11 Connector Pinouts for FXO Interface .....	30
Figure 5-9: Connecting FXO Interfaces.....	30
Figure 5-10: RJ-11 Connector Pinouts for FXS Lifeline .....	31
Figure 5-11: Cabling the FXS Analog Lifeline .....	31
Figure 5-12: Cabling Serial Port .....	32
Figure 5-13: Connecting USB Storage Device .....	33
Figure 5-14: AC/DC Power Adapter .....	34
Figure 5-15: Inserting Plug into Power Adapter.....	35
Figure 5-16: Cabling to Power using Power Adapter .....	36

## List of Tables

Table 3-1: Physical Dimensions and Operating Environment .....	13
Table 3-2: Front Panel Description .....	13
Table 3-3: Power LED Description .....	14
Table 3-4: Status LED Description .....	14
Table 3-5: Front Panel Description.....	15
Table 3-6: LAN LED Description.....	16
Table 5-1: RJ-45 Connector Pinouts for GE.....	23
Table 5-2: RJ-45 Connector Pinouts .....	32
Table 5-3: Power Specifications .....	34
Table 5-4: Power Adapter with Interchangeable Plugs .....	35

## Notice

Information contained in this document is believed to be accurate and reliable at the time of printing. However, due to ongoing product improvements and revisions, AudioCodes cannot guarantee accuracy of printed material after the Date Published nor can it accept responsibility for errors or omissions. Updates to this document can be downloaded from <https://www.audiocodes.com/library/technical-documents>.

This document is subject to change without notice.

Date Published: April-26-2018

## WEEE EU Directive

Pursuant to the WEEE EU Directive, electronic and electrical waste must not be disposed of with unsorted waste. Please contact your local recycling authority for disposal of this product.

## Customer Support

Customer technical support and services are provided by AudioCodes or by an authorized AudioCodes Service Partner. For more information on how to buy technical support for AudioCodes products and for contact information, please visit our Web site at <https://www.audiocodes.com/services-support/maintenance-and-support>.

## Abbreviations and Terminology

Each abbreviation, unless widely used, is spelled out in full when first used.

Throughout this manual, unless otherwise specified, the term *device* refers to Mediant 500L Gateway & E-SBC.

## Related Documentation

Document Name
SIP Release Notes
Mediant 500L Gateway & E-SBC User's Manual
CLI Reference Guide

## General Notes and Warnings, and Safety Information



**Warning:** Adhere to all warning statements in this document.



**Note:** Open source software may have been added and/or amended for this product. For further information, please visit our website at <https://www.audiocodes.com/services-support/open-source/> or contact your AudioCodes sales representative.



**Warning:** The device is an **INDOOR** unit and therefore, must be installed **only** indoors.



### Caution Electrical Shock

Do not open or disassemble this device. The device carries high voltage and contact with internal components may expose you to electrical shock and bodily harm.



**Warning:** The device must be installed and serviced only by qualified service personnel.



**Warning:** For deployment in Finland, Sweden and Norway, the device must be installed **only** in restricted access locations that are compliant with ETS 300253 guidelines where equipotential bonding has been implemented.



**Warning:** Disconnect the device from the mains and Telephone Network Voltage (TNV) before servicing.

## Document Revision Record

LTRT	Description
10480	Initial document release for Version 7.0.
10481	Connector pinouts updated for serial interface.
10482	Max. power consumption updated.
10483	Status LED for software upgrade.
10484	19-inch rack mount; wall mounting.
10485	AC power cable warning (Japanese).
10486	Wall-mounting template.
10487	FXS and FXO interfaces added.
10488	LAN FE changed to GE.
10489	Typo re 19-inch rack mount shelf.
10490	Logo updated; PSTN Fallback/Analog lifeline updated.
10491	Serial cabling updated.

## Documentation Feedback

AudioCodes continually strives to produce high quality documentation. If you have any comments (suggestions or errors) regarding this document, please fill out the Documentation Feedback form on our Web site at <https://online.audiocodes.com/documentation-feedback>.



# 1 Introduction

This document provides a hardware description of the Mediant 500L Gateway & E-SBC (hereafter referred to as *device*) and step-by-step procedures for mounting and cabling the device.

The device supports the following interfaces:

- Four Gigabit Ethernet (1000Base-T) LAN ports (RJ-45).
- One USB port for optional USB storage services.
- Up four ISDN BRI port interfaces, supporting up to eight voice channels as well as PSTN fallback.
- Up to four FXS port interfaces.
- Up to four FXO port interfaces.
- Serial console port (RJ-45) for device management.

**Notes:**

- Hardware configurations may change without notice. Currently available hardware configurations are listed in AudioCodes Price Book. For further enquiries, please contact your AudioCodes sales representative.
- For information on configuring the device, refer to the device's *User's Manual*.

**This page is intentionally left blank.**

## 2 Unpacking the Device

Follow the procedure below for unpacking the carton in which the device was shipped.

➤ **To unpack the device:**

1. Open the carton and carefully remove packing materials.
2. Remove the chassis from the carton.
3. Check that there is no equipment damage.
4. Ensure that in addition to the chassis, the package contains the following items:
  - Four anti-slide bumpers for desktop installation
  - AC/DC power adapter
5. Check, retain and process any documents.

If there are any damaged or missing items, notify your AudioCodes sales representative.

**This page is intentionally left blank.**

## 3 Physical Description

This section provides a physical description of the device.

### 3.1 Physical Dimensions and Operating Environment

The device's physical dimensions and operating environment are listed in the table below:

**Table 3-1: Physical Dimensions and Operating Environment**

Specification	Value
<b>Dimensions (H x W x D)</b>	51 x 296 x 160 mm (2 x 11.65 x 6.3 in.)
<b>Weight</b>	670 g (1.5 lbs.)
<b>Operating Environment</b>	<ul style="list-style-type: none"> <li>▪ Operational: 5 to 40°C (41 to 104°F)</li> <li>▪ Storage: -25 to 85°C (-13 to 185°F)</li> <li>▪ Relative Humidity: 10 to 90% non-condensing</li> </ul>

### 3.2 Front Panel Description

The front panel provides LEDs for indicating the status of various functionalities. The LEDs are shown in the figure below and described in the subsequent tables.

**Figure 3-1: Front Panel**



**Note:** The figure above is used only as an example. The available LEDs depend on the ordered hardware configuration.

**Table 3-2: Front Panel Description**

Item #	LED Label	Description
1	<b>Power</b>	Indicates the status of the power supply to the device. For more information, see Section 3.2.1 on page 14.
2	<b>Status</b>	Indicates the operating status of the device. For more information, see Section 3.2.1.2 on page 14.

### 3.2.1 LED Descriptions

The LED descriptions are provided in the subsequent subsections.

#### 3.2.1.1 Power LED

The **Power** LED indicates whether or not the device is powered on or off, as described in the table below.

**Table 3-3: Power LED Description**

Color	State	Description
Green	On	Power is received by the device.
-	Off	No power is received by the device.

#### 3.2.1.2 Status LED

The **Status** LED indicates the operating status, as described in the table below.

**Table 3-4: Status LED Description**

Color	State	Description
Green	On	Device is operational.
	Flashing	<ul style="list-style-type: none"> <li>▪ Initial rebooting stage.</li> <li>▪ Software upgrade (.cmp file) in process (currently supported only by Software Version 6.8).</li> </ul>
Red	On	Boot failure.
-	Off	Advanced rebooting stage.

### 3.3 Rear Panel Description

The device's rear panel is shown in the figure below and described in the subsequent table.

**Figure 3-2: Rear Panel**

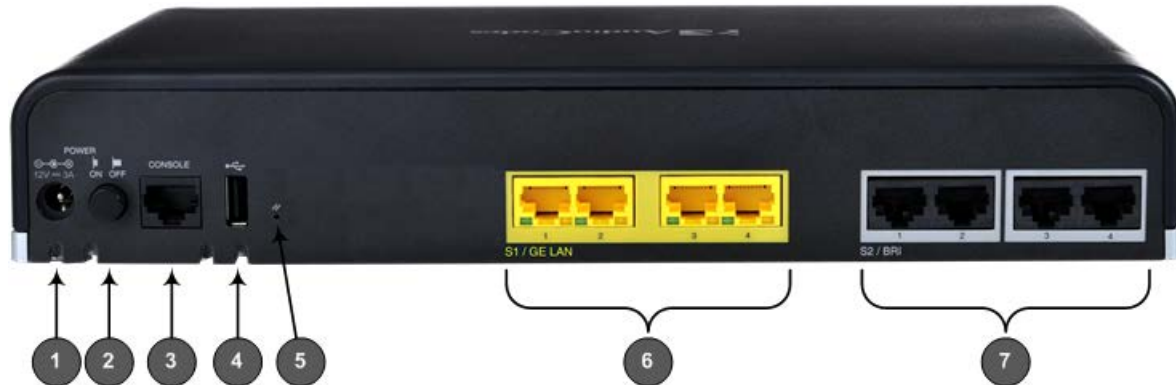

**Note:** The figure above is used only as an example. The hardware configuration depends on the ordered model.

**Table 3-5: Front Panel Description**

Item #	Label	Description
1	<b>POWER 12V -- 3A</b>	AC power supply plug entry for connecting the device to the external AC power supply adapter.
2	<b>ON / OFF</b>	Power button which powers on the device when pressed in and powers off the device when pressed again (pressed out).
3	<b>CONSOLE</b>	RJ-45 port for RS-232 serial communication with the device.
4		USB 2.0 port, which can be used for external USB hard drive or flash disk (disk on key) for USB storage capabilities (for example, for configuration file)
5	//	Reset pinhole button for resetting the device or for restoring it to factory defaults. To restore the device to factory defaults, do the following: With a paper clip or any other similar pointed object, press and hold down the pinhole button for <b>at least 12 seconds, but no longer than 25 seconds</b>
6	<b>S1 (Slot 1) GE LAN</b>	Up to four Gigabit Ethernet (1000Base-T) ports (RJ-45) for connecting to LAN network such as IP phones, computers, and switches. These ports support half- and full-duplex modes, auto-negotiation, and straight or crossover cable detection. For a description of the LAN LEDs, see Section 3.3.1 on page 16.
7	<b>S1 / S2 (Slot 1 / Slot 2) FXS / FXO / BRI</b>	Telephony interfaces, depending on ordered configuration: <ul style="list-style-type: none"> <li>Up to four ISDN BRI port interfaces (RJ-45)</li> <li>Up to four FXS port interfaces (RJ-11)</li> <li>Up to four FXO port interfaces (RJ-11)</li> </ul>

### 3.3.1 LAN Interface LEDs

Each Ethernet port provides a LED for indicating LAN operating status, as described in the table below.

**Table 3-6: LAN LED Description**

Color	State	Description
Green	On	Ethernet link established.
	Flashing	Data is being received or transmitted.
-	Off	No Ethernet link.



## 4 Mounting the Device

You can mount the device using one of the following methods:

- Desktop mounting
- 19-inch Rack mounting
- Wall mounting

### 4.1 19-Inch Rack Mounting

You can mount the device in a standard 19-inch rack, using AudioCodes 1U 19-inch rack mount shelf (not supplied).



**Note:** The AudioCodes 1U 19-inch rack mount shelf is not supplied with your product and can be ordered separately from an AudioCodes sales distributor.



**Warning:**

- Elevated Operating Ambient: If installed in a closed or multi-unit rack assembly, consideration should be given to installing the equipment in an environment compatible with the maximum ambient temperature (Tmax) of 40°C (104°F).
- Reduced Air Flow: Installation should be such that the amount of air flow required for safe operation on the equipment is not compromised. Do not stack equipment one on top of the other and keep the ventilation openings free from cables or any objects to allow free air circulation. The device must be mounted correctly on the rack mount shelf to avoid air blockage to the three vents located on the bottom of the device. Mounting the device on a shelf other than AudioCodes' rack mount shelf may cause the device to overheat, resulting in permanent damage to it.
- Only one device can be mounted per rack mount shelf.
- The minimum vertical rack space for mounting the device in a 19-inch rack must be 2Us (3.5 in. or 88.9 mm). See figure below.

**Figure 4-1: Minimum Vertical Space for 19-inch Rack Mounting**

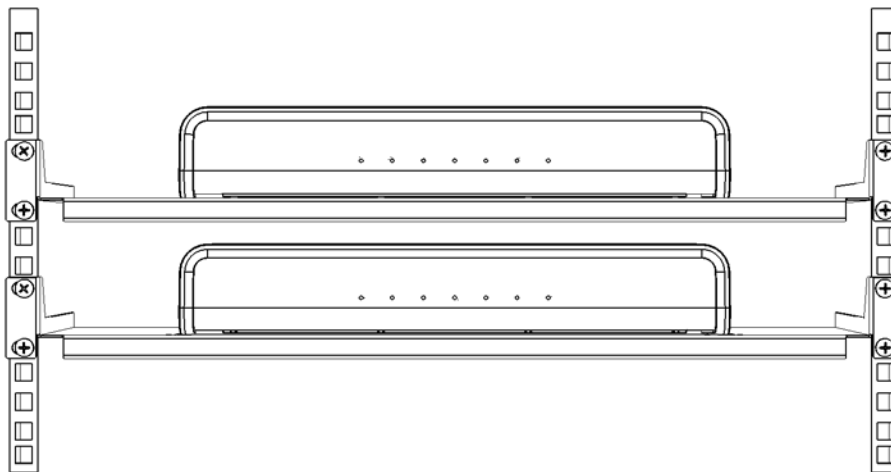

- **To mount the device in a 19-inch rack:**
1. Position the rack mount shelf (not supplied) in the 19-inch rack, aligning the holes of the shelf's side brackets with the holes of the rack's front posts, as shown in the figure below.

**Figure 4-2: Positioning Shelf in Rack**

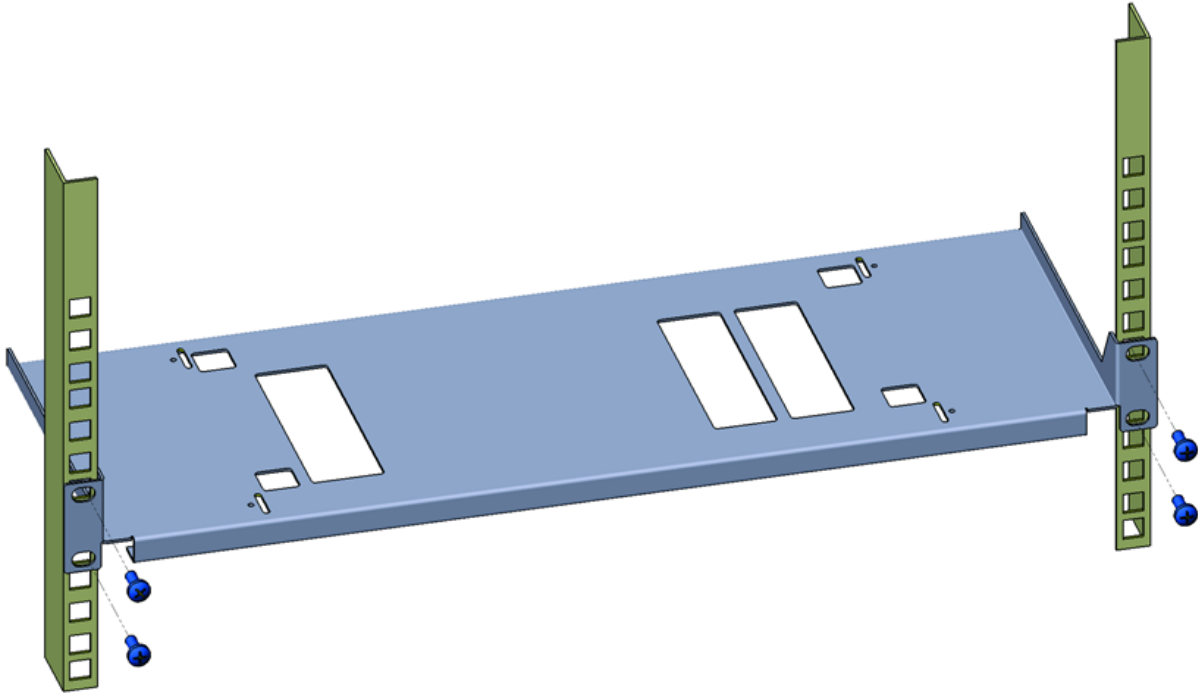

**Note:** Make sure that you attach the shelf's side brackets (left and right) at the same height level in the rack so that the shelf is in a horizontal position.

2. Attach the shelf to the rack posts using four standard 19-inch rack bolts (not supplied).

3. Place the device on the shelf so that the device's front panel faces the front of the rack and the device's four anti-slide rubber legs (located on the bottom of the device) fit into the four square openings on the shelf, as shown in the figure below (viewed from underneath):

**Figure 4-3: Positioning the Device's Anti-Slide Rubber Legs into Shelf's Openings**

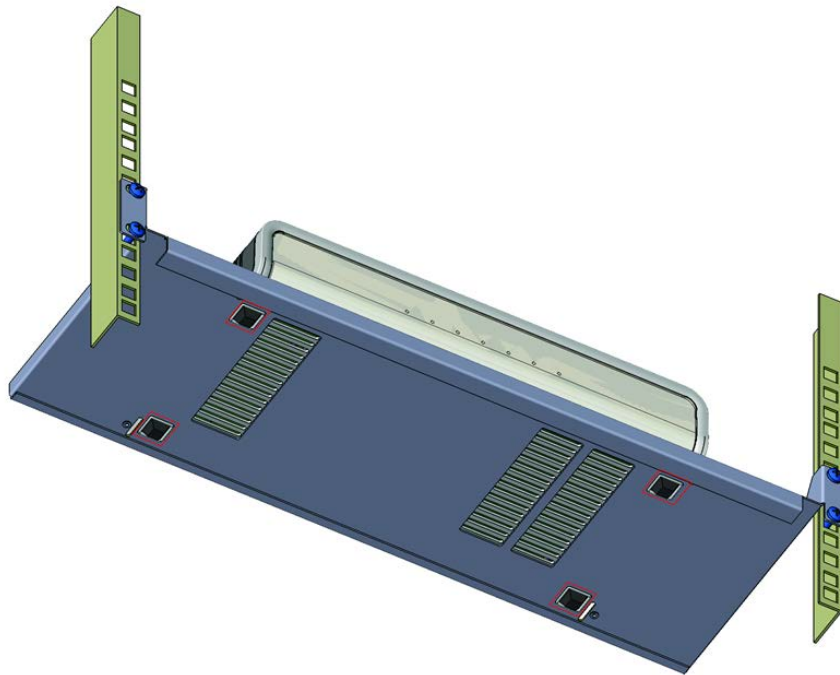

4. Make sure the device is firmly mounted on the shelf so it does not horizontally slide in any direction:

**Figure 4-4: Device Mounted on Shelf in 19-inch Rack**

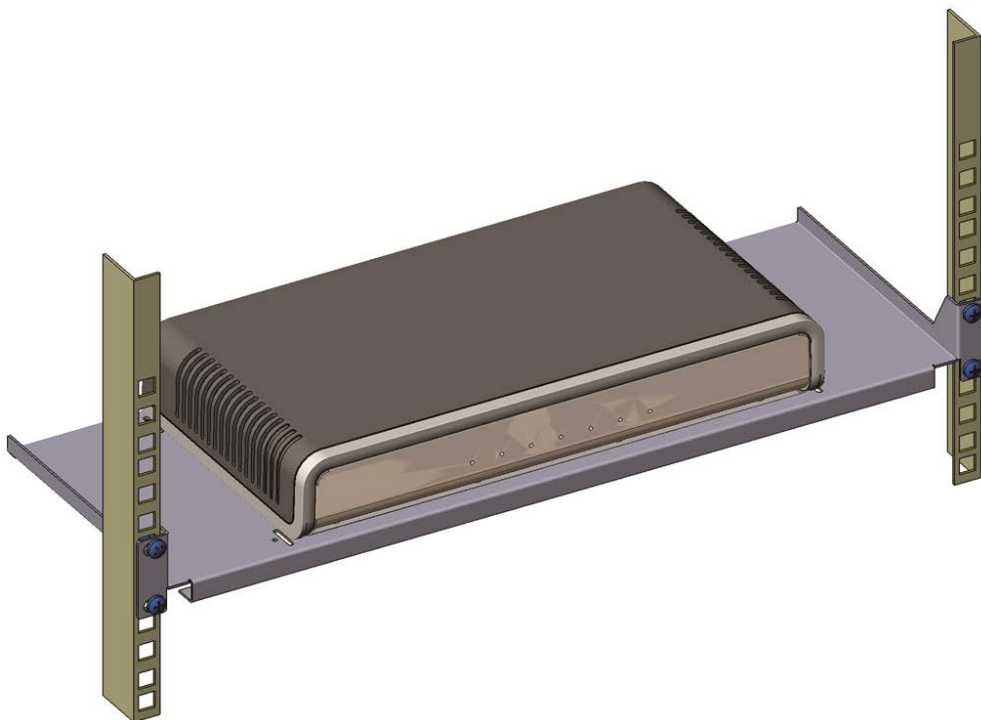

## 4.2 Wall Mounting

You can mount the device on a wall using the keyholes on the bottom of the device.

➤ **To mount the device on a wall:**

1. Drill three holes in the wall where you want to mount the device, using the distances between the holes as shown in the figure below:
  - Horizontal distance between the top two parallel holes: 89 mm (5.51 in.)
  - Vertical distance between the top two parallel holes and bottom hole: 204 mm (8.03 in.)
  - Horizontal distance between a top hole and the bottom hole: 44.5 (1.75 in.)

**Figure 4-5: Dimensions for Drilled Holes**

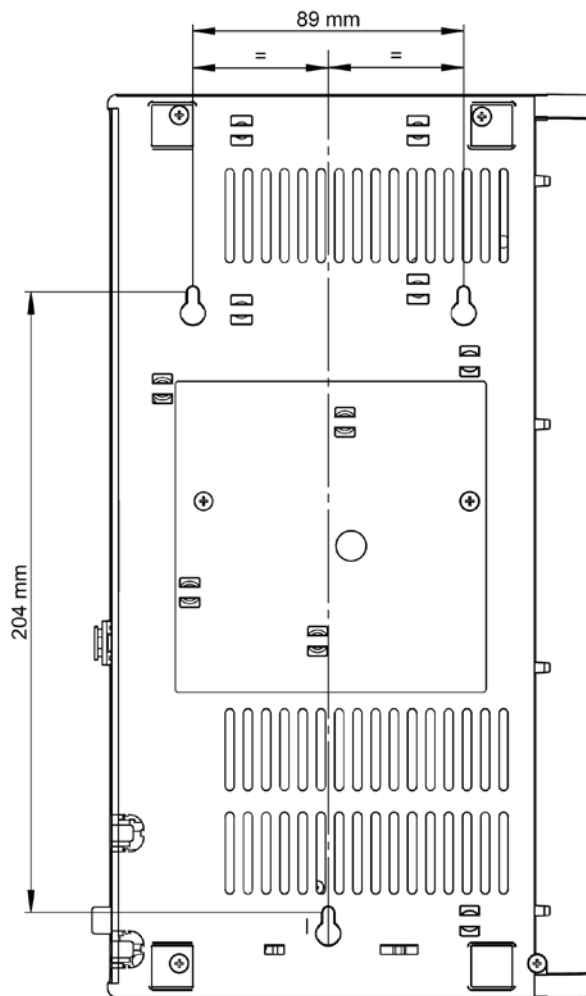

**Note:**

- When choosing the area on the wall to mount the device, make sure that sufficient space is available for attaching cables on the rear panel.
- Make sure that you drill the holes in the **same orientation** as shown in the above figure (i.e., two parallel holes on the top and the single hole on the bottom).
- Use the **mounting template** on the following page (print out) to mark the locations for the mounting holes on the wall.

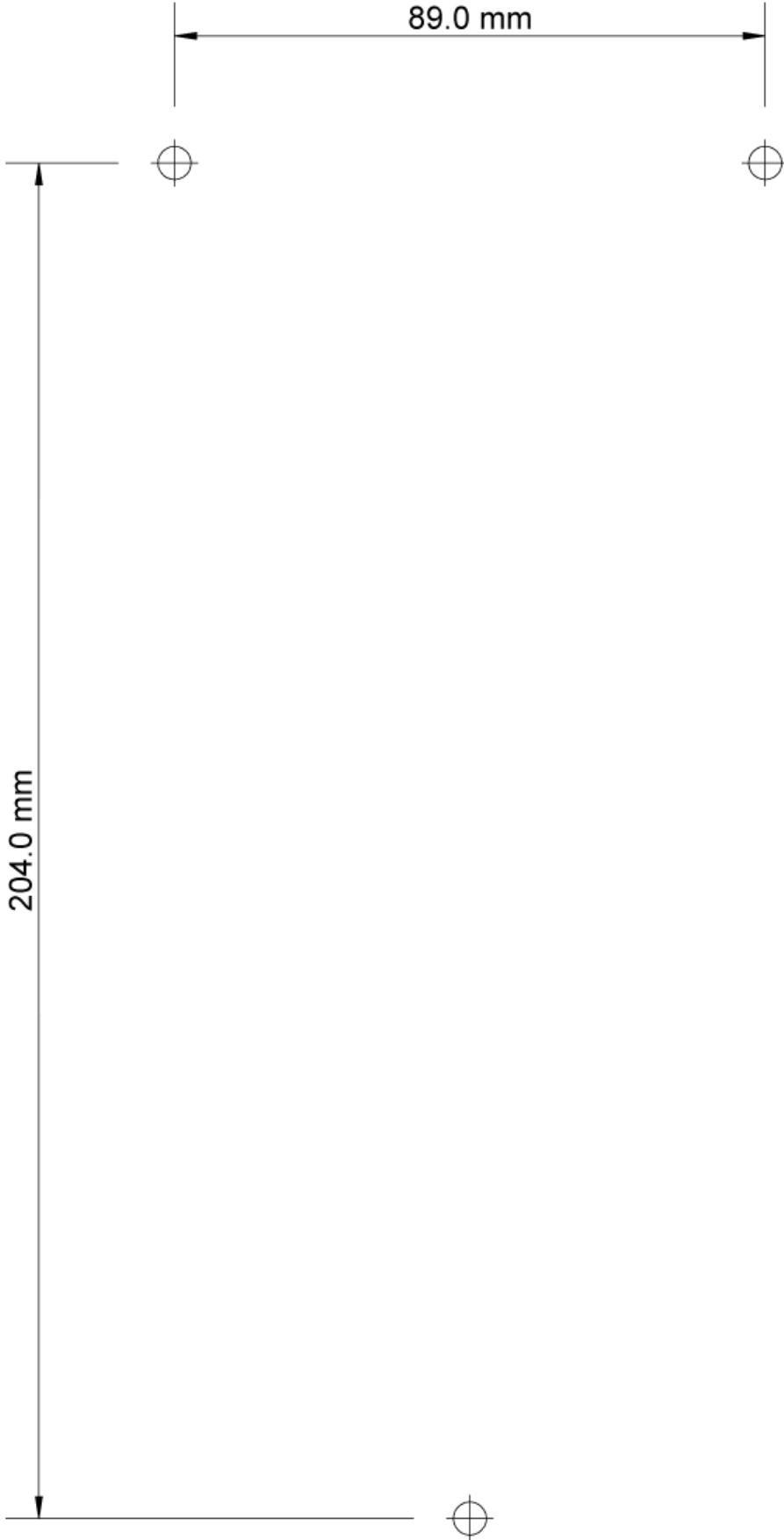

2. Insert wall anchors of the appropriate size into each hole.
3. Thread screws (not supplied) into each of the wall anchors. The recommended screw type is DIN 7982 3.5x25 Phillips flat head. Make sure that the heads extend sufficiently (about 4 mm or 0.157 in.) from the wall for the device's keyholes to hang on:

**Figure 4-6: Protruded Screw Distance from Wall Surface**

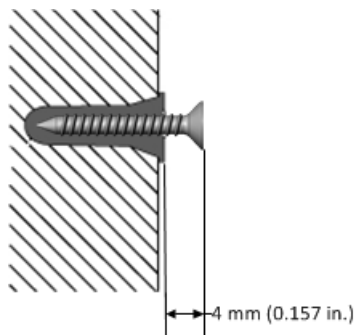

4. Hold the device so that it is orientated with the bottom panel with the keyholes facing the wall and the rear panel with the ports facing your right.
5. Mount the device on the wall by hanging the device's keyholes on the screw heads:

**Figure 4-7: Hanging Device on Screw Heads**

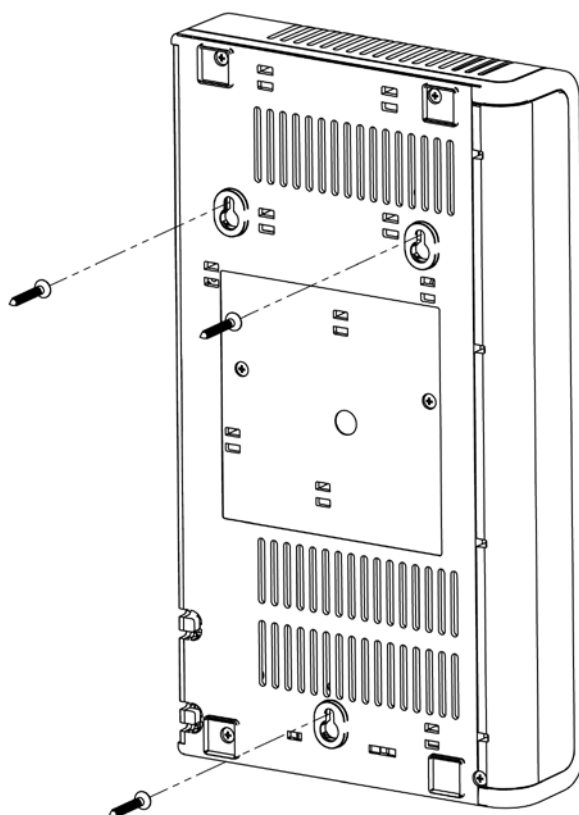

# 5 Cabling the Device

This chapter describes the cabling of the device.

## 5.1 Connecting LAN Interfaces

The device's Gigabit Ethernet LAN ports (1000Base-T) can be connected to network equipment and entities such as computers, switches, and IP phones. These ports support half- and full-duplex modes, auto-negotiation, and straight or crossover cable detection.

The Ethernet ports can operate in pairs (*Ethernet Groups*) to provide 1+1 port redundancy, where one port serves as the active port while the other as standby. When the active port fails, the device switches to the standby port. By default, the Ethernet ports are grouped into pairs, as shown in the figure below with the port string names used for software configuration. You can change this port assignment, including assigning only a single port to an Ethernet Group. For more information, refer to the *User's Manual*.

**Figure 5-1: Default Ethernet Port Groups and Port String Names for Software Configuration**

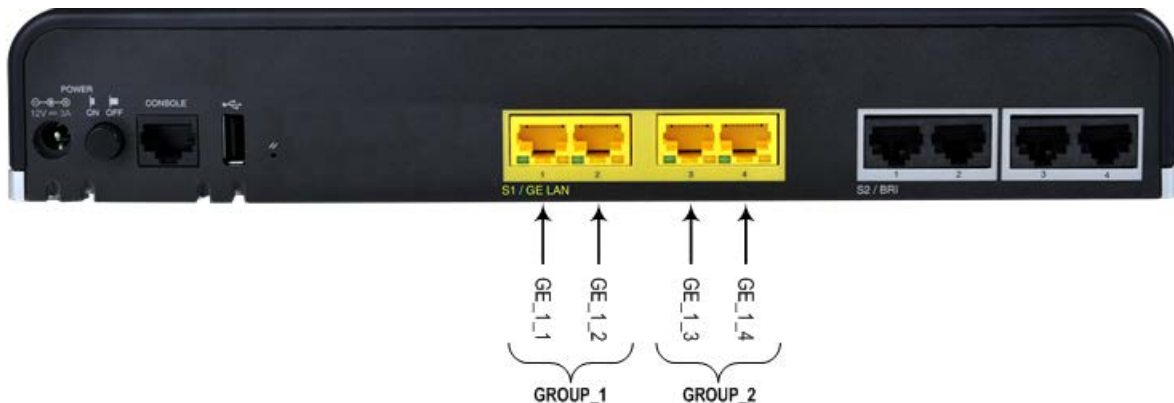

The Ethernet cabling specifications include the following:

- **Cable:** Straight-through, Category (Cat) 5e cable
- **Connector:** Standard RJ-45
- **Connector Pinouts:**

**Table 5-1: RJ-45 Connector Pinouts for GE**

Pin	Signal Name
1	Ethernet signal pair (1000Base-T)
2	
3	Ethernet signal pair (1000Base-T)
6	
4	Ethernet signal pair (1000Base-T)
5	
7	Ethernet signal pair (1000Base-T)
8	
Shield	Chassis ground

➤ **To connect the device to the LAN:**

1. Connect one end of a straight-through RJ-45 Cat 5e or Cat 6 cable to the LAN port, located on the rear panel and labeled **GE LAN**.

**Figure 5-2: Cabling LAN Ports**

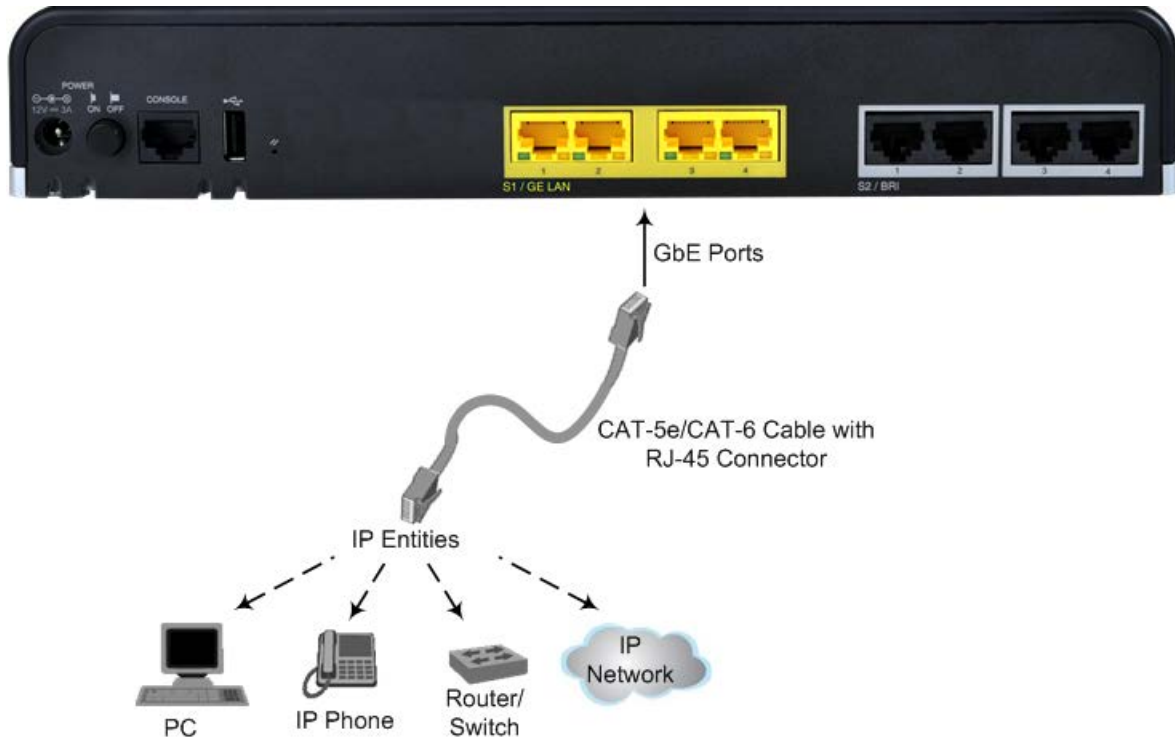

2. Connect the other end of the cable to a network device or entity.
3. For 1+1 LAN protection, repeat steps 1 and 2 for the standby port, but connect it to another network (but in the same subnet).



**Warning:** Ethernet port interface cabling must be routed only indoors and must not exit the building.



## 5.2 ISDN BRI Interfaces

This section describes how to connect the device to ISDN BRI lines.

### 5.2.1 Connecting BRI Lines

The BRI ports can be connected to ISDN terminal equipment such as ISDN telephones or PBXs. Each BRI port can be configured either as termination equipment/user side (TE) or network termination/network side (NT). Up to eight terminal equipment (TE) devices can be connected per BRI S/T port, using an ISDN S-bus providing eight ISDN ports. When configured as NT, the BRI port drives a nominal voltage of 38V with limited current supply of up to 100 mA.



**Warning:** To protect against electrical shock and fire, use a 26 AWG min wire to connect the BRI ports to the PSTN.



**Note:** BRI interface is a customer-ordered item which is supported only on specific hardware configurations. For more information, contact your AudioCodes sales representative.

The BRI cabling specifications include the following:

- **Cable:** Straight-through, Category (Cat) 5, 5e or 6
- **Connector:** Standard RJ-45
- **Connector Pinouts:**

Figure 5-3: RJ-45 Connector Pinouts for TE or NT BRI Ports

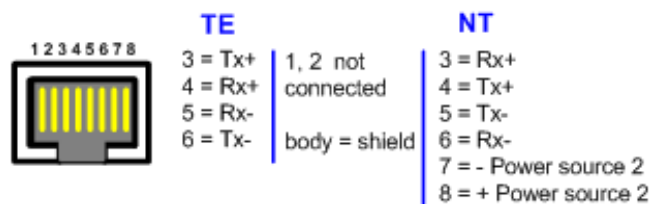

➤ **To connect a BRI line:**

1. Connect the RJ-45 cable to the device's BRI port, located on the rear panel and labeled **BRI**.

**Figure 5-4: Cabling BRI Ports**

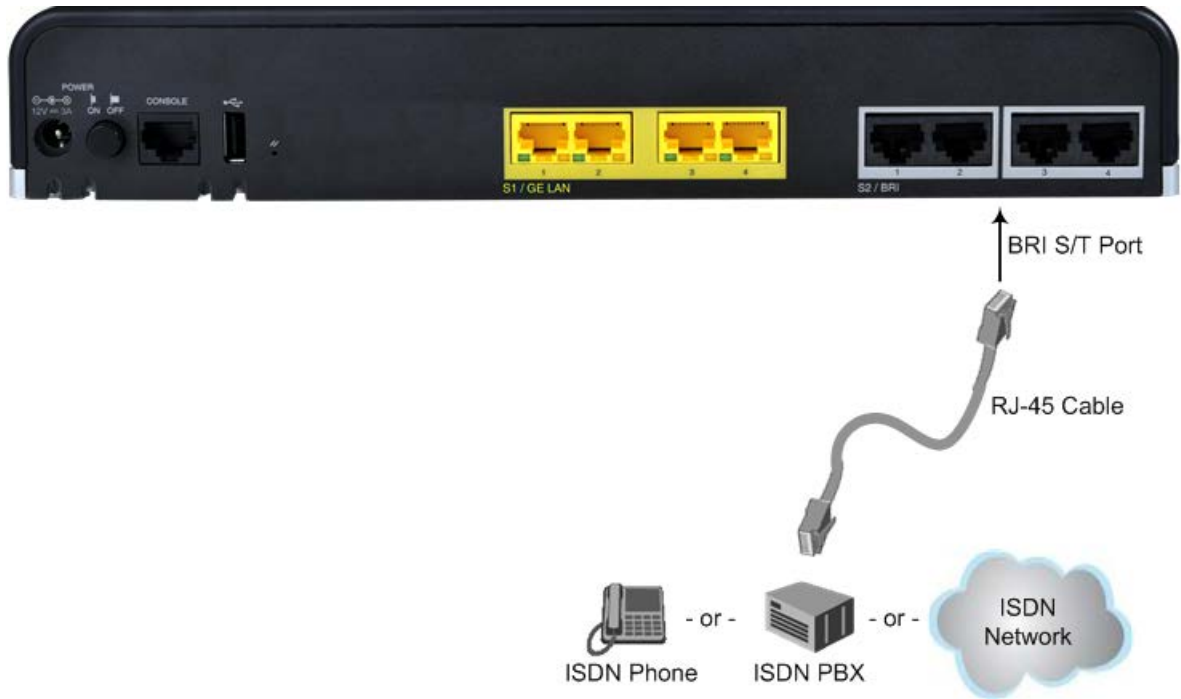

2. Connect the other end of the cable to your ISDN equipment.

## 5.2.2 Connecting PSTN Fallback for BRI Lines

The device supports PSTN Fallback for BRI lines. If the device loses power, for example, due to a power outage or the unplugging of its power cable, it automatically routes calls from the Tel side to the PSTN (instead of the IP network). This guarantees call continuity.

The BRI PSTN Fallback uses BRI ports #1 and #2. When the BRI PSTN Fallback is activated, the internal metallic relay switch of BRI port #1 automatically connects BRI ports #1 and #2, and calls can be routed and established between these entities.

➤ **To cable the BRI PSTN Fallback:**

1. Connect BRI line 1 (Port #1), located on the rear panel, to an ISDN PBX.
2. Connect BRI line 2 (Port #2), located on the rear panel, to the ISDN network (PSTN).

**Figure 5-5: Cabling BRI PSTN Fallback**

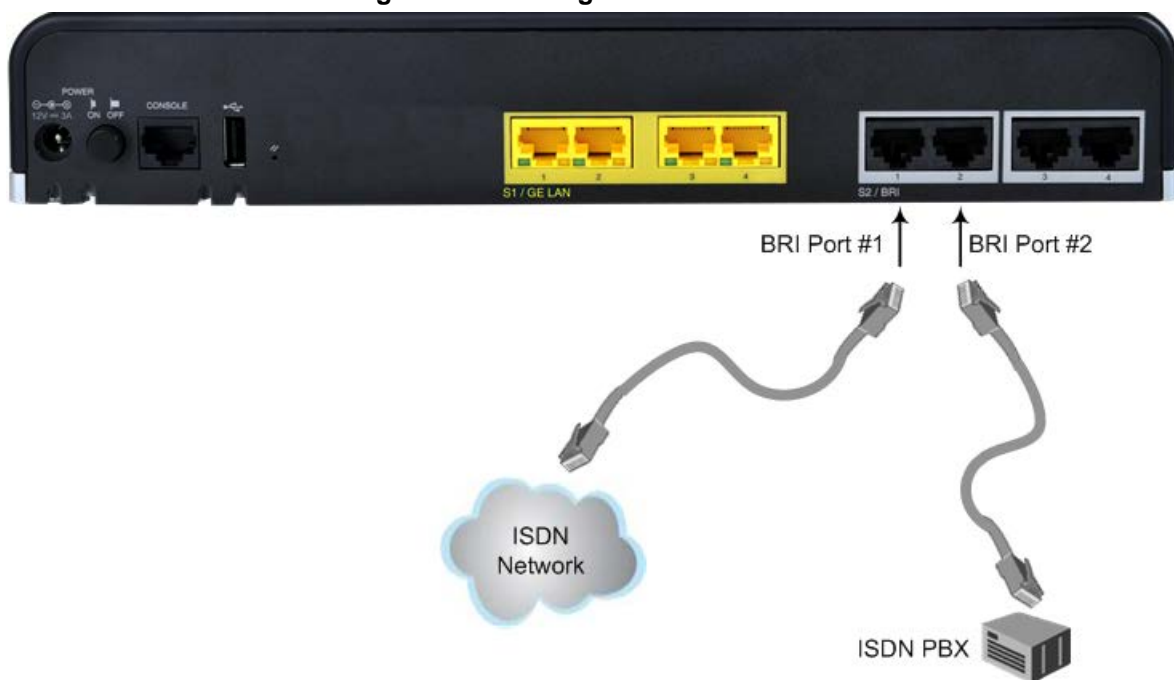

**Notes:**

- For the four-BRI port configuration, fallback is not supported on ports #3 and #4.
- The BRI PSTN Fallback feature is a customer-ordered item, which is supported only on specific hardware configurations providing BRI interfaces. For more information, contact your AudioCodes sales representative.
- The BRI PSTN Fallback feature has no relation to the PSTN Fallback Software License Key.



## 5.3 Analog Interfaces

This section describes how to connect the device to analog equipment.

### 5.3.1 Connecting FXS Interfaces

The procedure below describes how to cable the device's FXS interfaces.



**Warnings:**

- The device is an **INDOOR** unit and therefore, must be installed only indoors.
- FXS port interface cabling must be routed **only indoors** and must not exit the building.
- Make sure that the FXS ports are connected to the appropriate, external devices; otherwise, damage to the device may occur.
- FXS ports are considered TNV-2.



**Notes:**

- FXS interface is a customer-ordered item.
- FXS is the interface replacing the Exchange (i.e., the CO or the PBX) and connects to analog telephones, dial-up modems, and fax machines. The FXS is designed to supply line voltage and ringing current to these telephone devices. An FXS VoIP device interfaces between the analog telephone devices and the Internet.

**Cable specifications:**

- **Cable:** Standard straight-through RJ-11-to-RJ-11 telephone cable
- **Connector Type:** RJ-11
- **Connector Pinouts:**

**Figure 5-6: RJ-11 Connector Pinouts for FXS Interface**

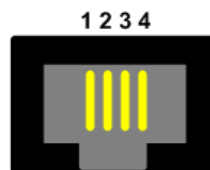

- 1 - Not connected
- 2 - Tip
- 3 - Ring
- 4 - Not connected

➤ **To connect the FXS interfaces:**

1. Connect one end of an RJ-11 cable to the device's FXS port (labeled **FXS**), located on the rear panel:

**Figure 5-7: Connecting FXS Interfaces**

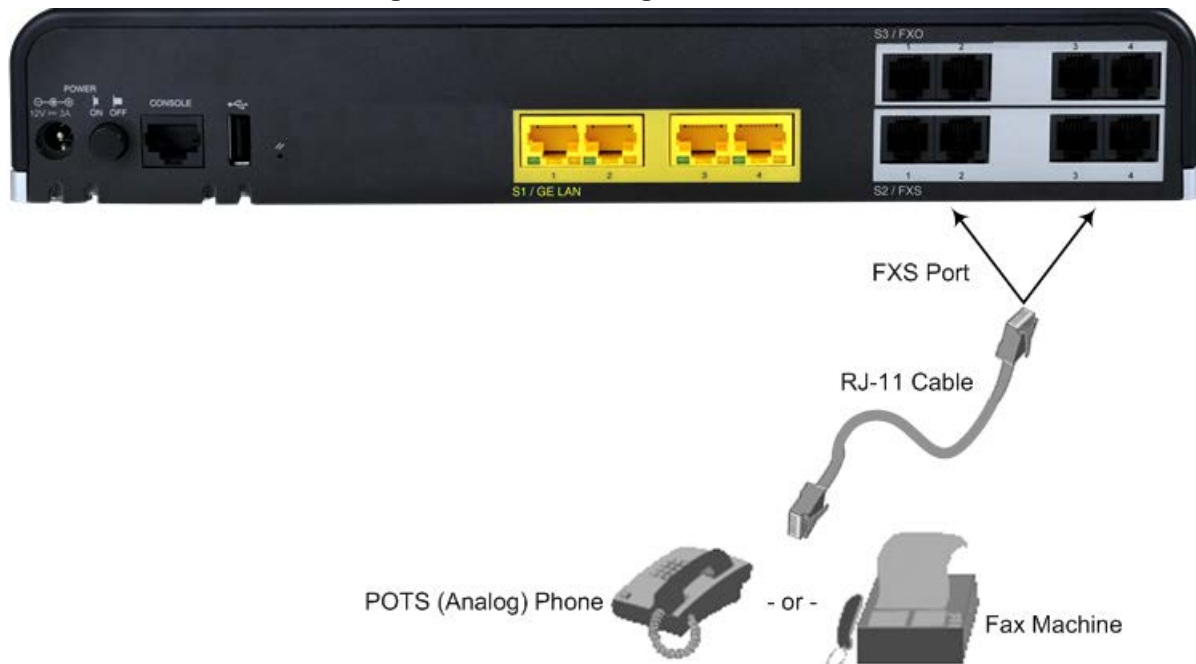

2. Connect the other end of the cable to the required telephone interface (e.g., fax machine, dial-up modem, or analog POTS telephone).

### 5.3.2 Connecting FXO Interfaces

The procedure below describes how to cable the device's FXO interfaces.



**Warnings:**

- The device does **not** include primary telecom protection! When the **FXO** telephone lines are routed **outside the building**, additional protection - usually a 350V three-electrode Gas Discharge Tube (GDT) as described in ITU-T K.44 - **must** be provided at the entry point of the telecom wires into the building (usually on the main distribution frame / MDF), in conjunction with proper grounding. The center pin of the GDT (MDF grounding bar) must be connected to the equipotential grounding bus bar of the Telecommunication room.
- To protect against electrical shock and fire, use a minimum 26-AWG wire to connect FXO ports to the PSTN.
- Ensure that the FXO ports are connected to the appropriate, external devices; otherwise, damage to the device may occur.
- FXO ports are considered TNV-3.



**Notes:**

- FXO interface is a customer-ordered item.
- FXO is the interface replacing the analog telephone and connects to a Public Switched Telephone Network (PSTN) line from the Central Office (CO) or to a Private Branch Exchange (PBX). The FXO is designed to receive line voltage and ringing current, supplied from the CO or the PBX (similar to an analog telephone). An FXO VoIP device interfaces between the CO/PBX line and the Internet.

**Cable specifications:**

- **Cable:** 26 AWG min
- **Connector Type:** RJ-11
- **Connector Pinouts:**

**Figure 5-8: RJ-11 Connector Pinouts for FXO Interface**

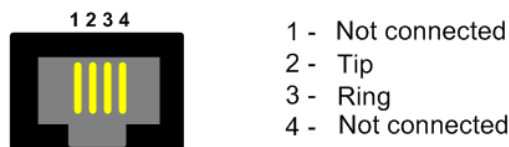

➤ **To connect the FXO interfaces:**

1. Connect one end of an RJ-11 cable to the device's FXO port (labeled **FXO**), located on the rear panel:

**Figure 5-9: Connecting FXO Interfaces**



2. Connect the other end of the cable to the required telephone interface: (e.g., telephone exchange analog lines or PBX extensions).

### 5.3.3 Connecting the FXS Analog Lifeline

The device supports Analog Lifeline. If the device loses power, for example, due to a power outage or the unplugging of its power cable, it automatically routes calls from a POTS telephone ("lifeline" phone), connected to an FXS port, to the PSTN (instead of the IP network).

The FXS Lifeline extension or phone connects to FXS Port #1 while the PSTN/PBX connects to FXO Port #1. When the Lifeline is triggered, the FXS line automatically connects to the FXO line and calls between these entities can occur.



**Note:** The FXS Analog Lifeline feature is a customer-ordered item and is only supported on specific hardware configurations with combined FXS and FXO interfaces. For more information, contact your AudioCodes sales representative.

#### Cable specifications:

- **Connector Types:** RJ-11
- **Connector Pinouts:**

**Figure 5-10: RJ-11 Connector Pinouts for FXS Lifeline**

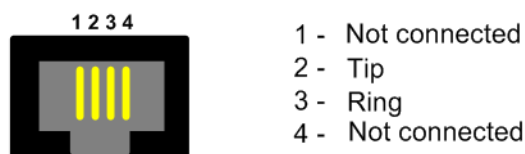

#### ➤ To cable the FXS Analog Lifeline:

1. Connect the analog lifeline telephone to FXS Port #1 (labeled **FXS**), located on the rear panel.
2. Connect an analog PSTN line to FXO Port #1 (labeled **FXO**), located on the rear panel.

**Figure 5-11: Cabling the FXS Analog Lifeline**

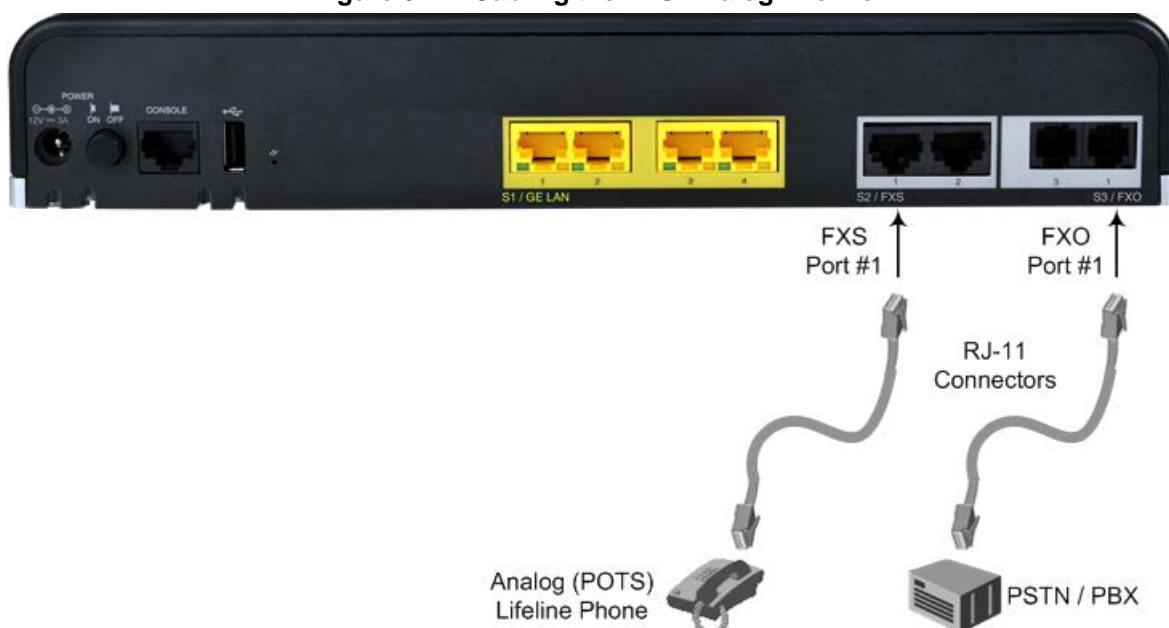

## 5.4 Cabling the Serial Interface to a PC

The device provides an RS-232 serial interface port on its rear panel. The RS-232 interface port is used to access the device's command line interface (CLI).

Cabling specifications:

- **Cable:** Straight-through, Category (Cat) 5, 5e or 6
- **Connector:** Standard RJ-45
- **Connector Pinouts:**

**Table 5-2: RJ-45 Connector Pinouts**

RJ-45	
Pin	Signal
1	Not used
2	Ground (GND)
3	Transmit Data (TXD)
4	Not used
5	Not used
6	Receive Data (RXD)
7	Ground (GND)
8	Not used

➤ **To connect the device's serial interface port to a PC:**

1. Connect the RJ-45 connector at the end of the cable to the device's serial port, located on the rear panel and labeled **CONSOLE**.

**Figure 5-12: Cabling Serial Port**

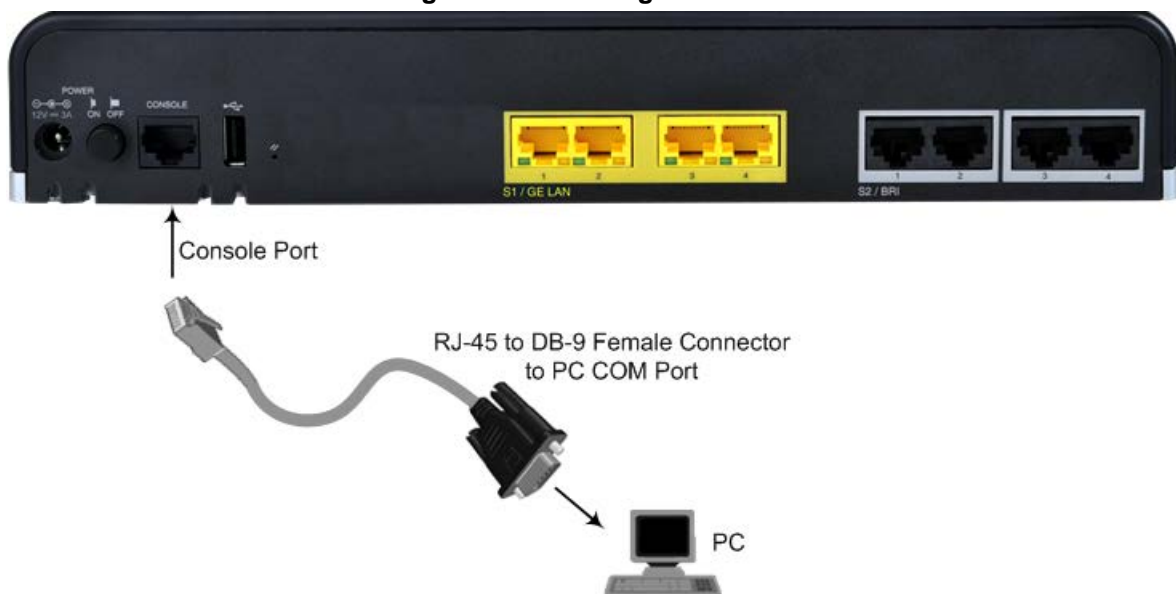

2. Connect the other end of the cable (e.g., 9-pin DB connector) to the COM RS-232 communication port on your computer.



## 5.5 Connecting a USB Storage Device

The device supports USB storage capabilities, using an external USB hard drive or flash disk (disk on key) connected to the device's USB port. The storage capabilities are configured through CLI and include the following:

- Saving network captures to USB
  - Upgrading the device's firmware from USB
  - Updating the device's configuration from USB
  - Saving the current configuration to USB
- **To connect the USB storage device:**
- Connect the USB storage device to the USB port, located on the rear panel.

**Figure 5-13: Connecting USB Storage Device**



**Note:** Only a single USB storage (formatted to FAT/FAT32) operation is supported at any given time.

## 5.6 Connecting to the Power Supply

The device is powered by an external 12V AC/DC power adapter (supplied), connected to a standard alternating current (AC) electrical wall outlet.

**Table 5-3: Power Specifications**

Item	Description
<b>Power Supply</b>	Single universal external AC power supply
<b>Input Ratings</b>	100-240 VAC, 50-60 Hz
<b>Output Ratings</b>	12V/3A
<b>Max. Power Consumption</b>	<ul style="list-style-type: none"> <li>▪ <b>Only SBC (no BRI):</b> 7W</li> <li>▪ <b>BRI:</b> <ul style="list-style-type: none"> <li>✓ 2.5W per NT port</li> <li>✓ 0.4W per TE port</li> </ul> </li> </ul>



**Warning:** Use only the AC/DC power adapter supplied with the device.



**ご注意**

本製品に添付の電源ケーブルは、Mediant 500L Gateway & E-SBCに専用設計されているため、汎用性はありません。本電源ケーブルを他の機器に使用されないよう、ご注意ください。

The device is shipped with the AC/DC power adapter shown in the figure below. The power adapter also supports interchangeable plugs to suite the electrical wall outlet type requirement of the country in which the device is being installed.

**Figure 5-14: AC/DC Power Adapter**

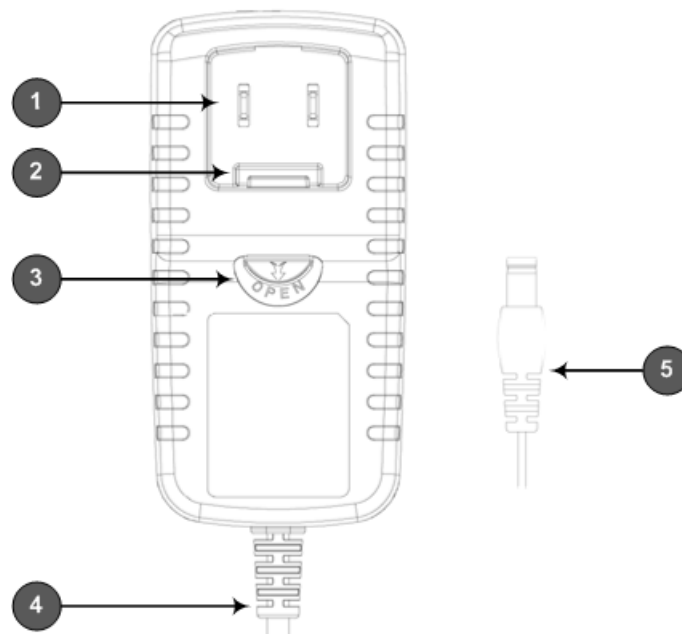
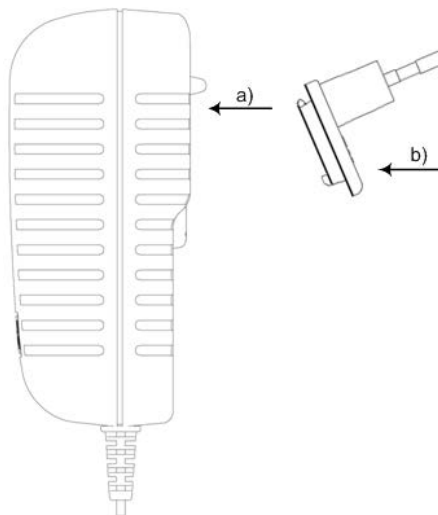

**Table 5-4: Power Adapter with Interchangeable Plugs**

Item	Description
1	Plug slot
2	Plug lock
3	Plug release lever
4	DC power cord
5	DC power plug

➤ **To connect the device to the power supply using the power adapter:**

1. Insert the relevant AC plug into the housing power adapter:
  - a. Insert the top part of the plug into the upper part of the housing slot (1).
  - b. Press down on the bottom part of the plug until a "click" sound is heard, indicating that the plug is securely inserted in the housing slot. To remove the plug, push and slide down the OPEN plug release lever (3).

**Figure 5-15: Inserting Plug into Power Adapter**

2. Insert the DC plug (5) located at the end of the power cord (4) of the power adapter into the device's power socket located on the rear panel.

Figure 5-16: Cabling to Power using Power Adapter

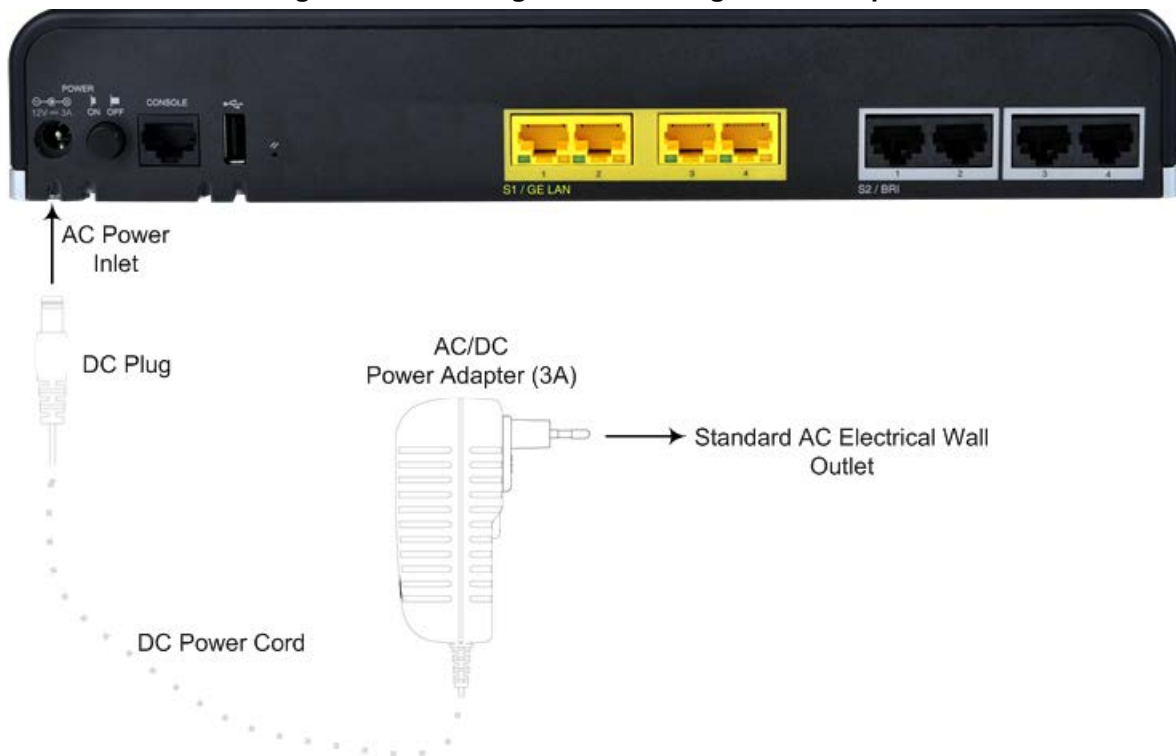

3. Plug the power adapter directly into a standard electrical wall outlet.

## 5.6.1 Powering On or Off the Device

The device is equipped with a power switch, which is located on its rear panel (see Section 3.3 on page 15) for turning it on or off.

➤ **To power on the device:**

- Press in the power button; the device receives power, indicated by the lighting of the **Power** LED, located on the front panel.

➤ **To power off the device:**

- Press out the power button; the device powers off, indicated by the **Power** LED going off.

**International Headquarters**

1 Hayarden Street,  
Airport City  
Lod 7019900, Israel  
Tel: +972-3-976-4000  
Fax: +972-3-976-4040

**AudioCodes Inc.**

27 World's Fair Drive,  
Somerset, NJ 08873  
Tel: +1-732-469-0880  
Fax: +1-732-469-2298

**Contact us:** <https://www.audiocodes.com/corporate/offices-worldwide>

**Website:** <https://www.audiocodes.com/>

©2018 AudioCodes Ltd. All rights reserved. AudioCodes, AC, HD VoIP, HD VoIP Sounds Better, IPmedia, Mediant, MediaPack, What's Inside Matters, OSN, SmartTAP, User Management Pack, VMAS, VoIPerfect, VoIPerfectHD, Your Gateway To VoIP, 3GX, VocaNom, AudioCodes One Voice and CloudBond are trademarks or registered trademarks of AudioCodes Limited. All other products or trademarks are property of their respective owners. Product specifications are subject to change without notice.

Document #: LTRT-10491

